

CUS400M

AC/DC Power Supply Series

APPLICATION NOTE

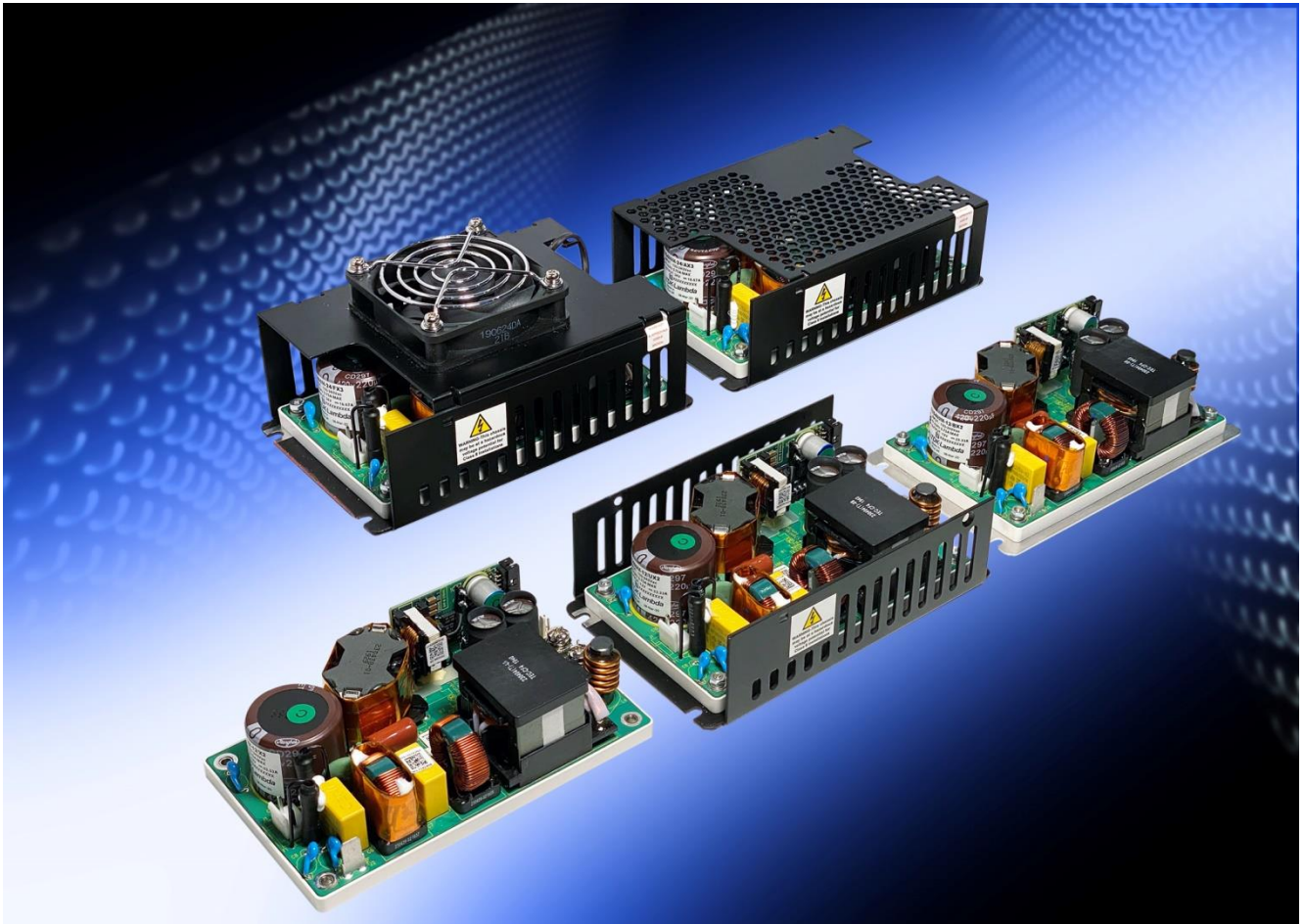

Contents

Contents	2
1. INPUT	3
AC INPUT LINE REQUIREMENTS	3
2. DC OUTPUT	3
OUTPUT VOLTAGE ADJUSTMENT.....	3
REMOTE SENSE	3
3. CONNECTIONS	4
4. GENERAL OPERATION.....	6
EFFICIENCY	6
NO LOAD OPERATION	7
CAPACITIVE LOAD OPERATION	7
SERIES CONNECTION	7
PARALLEL CONNECTION	7
OUTPUT CHARACTERISTICS	7
RIPPLE AND NOISE	7
TRANSIENT RESPONSE PERFORMANCE	8
FAN SUPPLY	9
OUTPUT TIMING	9
Output timing diagram.....	9
OVERSHOOT AT TURN-ON AND TURN-OFF	11
OUTPUT PROTECTION	12
Overcurrent Protection.....	12
Short Circuit Protection	12
Over-temperature Protection	12
Overvoltage Protection	12
5. COOLING REQUIREMENTS	13
CONVECTION AND CONDUCTION COOLING	13
FORCED AIR COOLING	15
6. RELIABILITY	15
ELECTROLYTIC CAPACITOR LIFETIMES.....	16
Example life curves for a convection cooled CUS400M-12 are presented below:	16
7. ELECTROMAGNETIC COMPATIBILITY	19
Example Conducted Emissions result for the CUS400M at 115VAC, 400W, Class I (/F configuration)	19
Example Conducted Emissions result for the CUS400M at 230VAC, 400W, Class II (/F configuration)	20
Example Radiated Emissions result for the CUS400M at 230VAC, 400W, Class I (/F configuration)	21
Example Radiated Emissions result for the CUS400M at 115VAC, 400W, Class II (/F configuration) FCC Limits	22
INSTALLATION FOR OPTIMUM EMC PERFORMANCE	23
Mounting	23
Cables	23
Earth Star Point.....	23
ESD Protection	23
Switching Frequency.....	23
8. MECHANICAL.....	24
Weight.....	24
Outline Drawings.....	24

1. INPUT

AC INPUT LINE REQUIREMENTS

Please refer to the datasheet for specifications of input line requirements (including input voltage range, input frequency, input harmonics, input current and leakage current).

The power supply will automatically recover from loss of AC power and start up with maximum loading at 85VAC. The output power derating for continuous operation for AC input voltages below 115V is 1%/V.

Repetitive ON/OFF cycling of the AC input voltage is not recommended.

- **Input Fuses**
Two internal fuses are fitted, one in each AC line. These fuses are not user serviceable. Fuses are rated for 8A and 250VAC.

In the /E option, one internal fuse is fitted in the Line (L) connection.
- **Input Under-voltage**
The power supply is protected against the application of an input voltage below the minimum specified so that it shall not cause damage to the power supply. The turn on voltage is 80VAC, turn off voltage is 70VAC. (Full load, 25°C ambient)

2. DC OUTPUT

OUTPUT VOLTAGE ADJUSTMENT

The output voltage can be adjusted via the trimmer R1 located next to the output terminals. The power supply's output voltage shall not be adjusted outside of the adjustment range specified above. The product can also be ordered with the output voltage adjusted to required voltage (Factory Set). The requested voltage must be within the range specified below (Consult technical sales).

Model	Nominal output voltage	Adjustment range
CUS400M-12	12V	12–13.2V
CUS400M-24	24V	24–26.4V

REMOTE SENSE

Remote sense connections are available in the model fitted with an option board ('X' option, e.g. in CUS400M-24/BX2 product code). The remote sense connections can be used to compensate for cable drops of up to 0.5V total on CH1. Permanent PSU failure may be caused if the remote sense is connected incorrectly (see guidelines below). The power supply's output voltage shall not be adjusted outside the specified adjustment range while using SENSE terminal connections to the load.

Please follow the guidelines below.

- If remote sense is not required, +SENSE (pin J5-4) and –SENSE (pin J5-6) can be left unconnected.
- If remote sense is required, +SENSE and –SENSE should be connected to the corresponding point at the load. The sense cables should be twisted together if possible.
- Remote sense shall not be connected across an output fuse.
- Care should be taken to connect the remote sense in the correct polarity and disconnect them from the load before the power connections are removed.

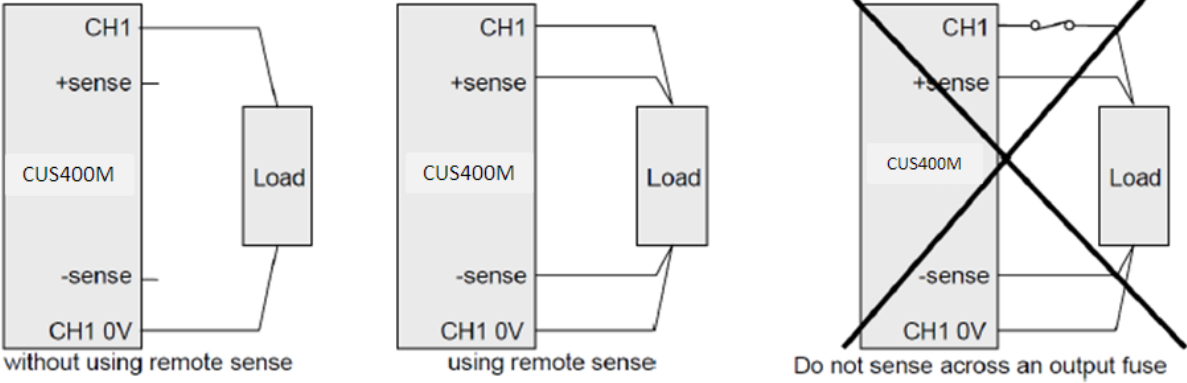

3. CONNECTIONS

Input connector J1 (JST connector)

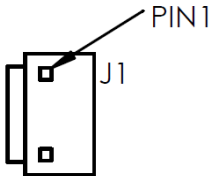

Pin	Connection
1	AC Neutral
2	Not connected
3	AC Line

JST mating connectors and pins

- Mating Housing Part no. VAR-2
- Crimp terminal (20~16AWG) Part no. SVA-41T-P1.1

Input connector J1 (Molex connector option /M)

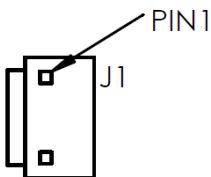

Pin	Connection
1	AC Neutral
2	Not connected
3	AC Line

Molex mating connectors and pins

- Mating Housing Part no. 09-50-1031
- Crimp terminal (24~18AWG) Part no. 08-70-1031

Contact Molex for other crimp terminal types

Output J3 and J4 (M4 screw terminal)

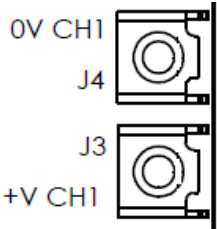

Terminal	Connection
J3	+V CH1
J4	0V CH1

Output connector information (J3 and J4)

- Manufacturer Molex
- Crimp pin (10~12AWG) Part no. TAG 19073-0165

Earth Ground J2

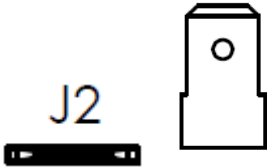

Pin	Connection
N/A	Protective Earth

Earth tab information (J2)

- Manufacturer Tyco
- Crimp terminal Part no. 2-520407-2

Contact Tyco for other crimp terminal types

Fan Supply J6 (Molex Connector)

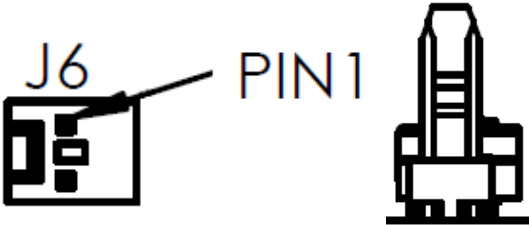

Pin	Connection
1	+V fan
2	0V fan ⁽¹⁾

(1) '0V fan' and '0V CH1' are internally connected

Molex mating connectors and pins

- 2 way Mini-Latch™ with locking ramp Part no. 51191-0200
- Crimp terminal Series 50802

Contact Molex for other crimp terminal types

Option board J5 (Molex Connector)

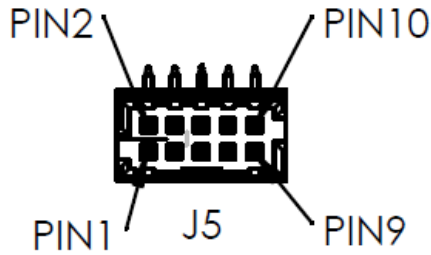

Pin	Connection
1	0V STANDBY ⁽²⁾
2	REMOTE ON/OFF -
3	+V STANDBY
4	+ SENSE
5	REMOTE ON/OFF +
6	- SENSE
7	AC_FAIL - COLLECTOR
8	DC_OK COLLECTOR
9	AC_FAIL - EMITTER
10	DC_OK EMITTER

(2) '0V STANDBY' and '0V CH1' are isolated from each other

Molex mating connectors and pins

- Mating Housing Part no. 51110-1051
- Crimp terminal Part no. 50394

Contact Molex for other crimp terminal types

4. GENERAL OPERATION

EFFICIENCY

Example efficiency achieved by CUS400M-12 and CUS400M-24 is shown for different output load conditions.

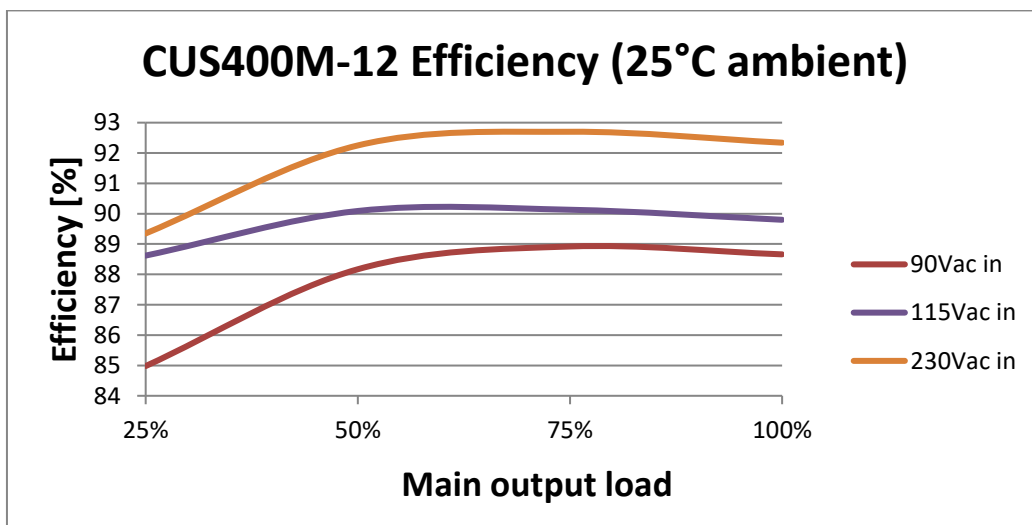

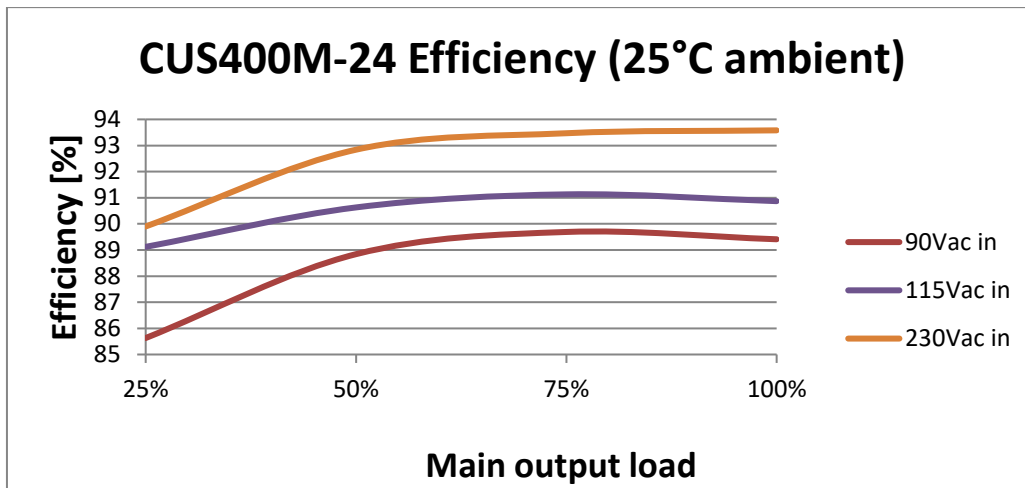

Note: For 90VAC line input, the maximum output power is linearly derated to 300W (1%/V).

NO LOAD OPERATION

No minimum load is required for the power supply to operate within specification. The power supply is capable of operating with no load on the output without any damage, hazardous conditions or reduction in performance.

CAPACITIVE LOAD OPERATION

The specifications for maximum external capacitance connected to the output are listed below.

Product code	CUS400M	
Output voltage	12V	24V
Maximum capacitance	33000µF	16700µF

The unit starts with 80% load max when CH1 voltage is adjusted between 105 and 110% of its nominal value.

SERIES CONNECTION

Please contact Technical Sales for guidance.

PARALLEL CONNECTION

Outputs shall not be connected in parallel as this may cause overheating and reduced field life.

OUTPUT CHARACTERISTICS

RIPPLE AND NOISE

Ripple and noise is defined as periodic or random signals over a frequency range of 10Hz to 20MHz. Measurements are made with a 20MHz bandwidth oscilloscope. Measurements are taken at the end of a 150mm length of a twisted pair of cables, terminated in a ripple probe with a 1MHz bandwidth, connected to the oscilloscope by a length of co-axial cable:

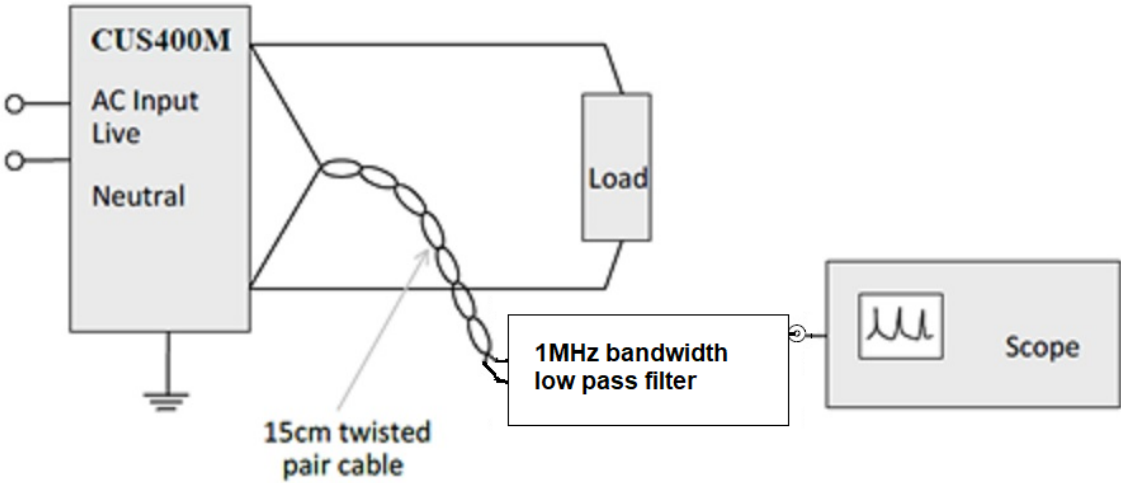

Ripple and Noise Measurement

TRANSIENT RESPONSE PERFORMANCE

The transient response specification refers to a 25-75% load change, 100Hz repetition rate, 50% duty cycle at 25°C ambient temperature

Dynamic Load Response (25°C or higher ambient)

For a 25 to 75 % load change, the output voltage will remain within 5% of the nominal output voltage and recover to within 2% of the nominal output voltage in ≤ 1 ms. Additional capacitance can be added across the output to reduce over/undershoots.

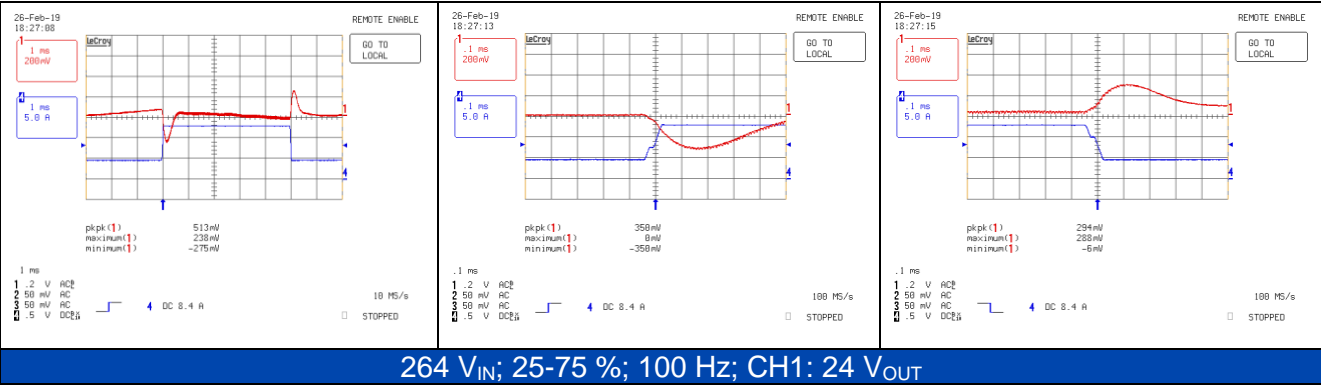
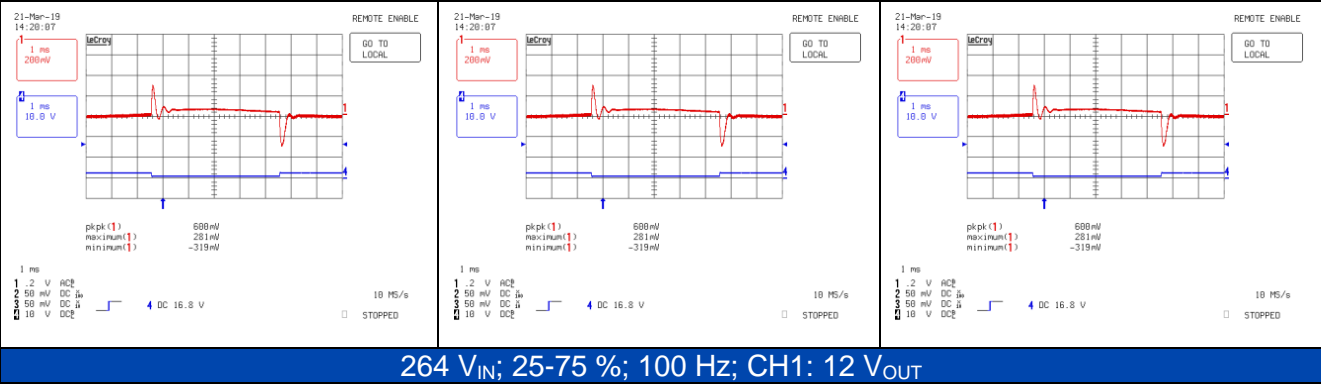

FAN SUPPLY

The fan supply output has a voltage range of 7 to 13.2V and is capable of providing current up to 300mA. The fan speed varies depending on the load on the power supply's main output (higher output load results in higher fan speed).

OUTPUT TIMING

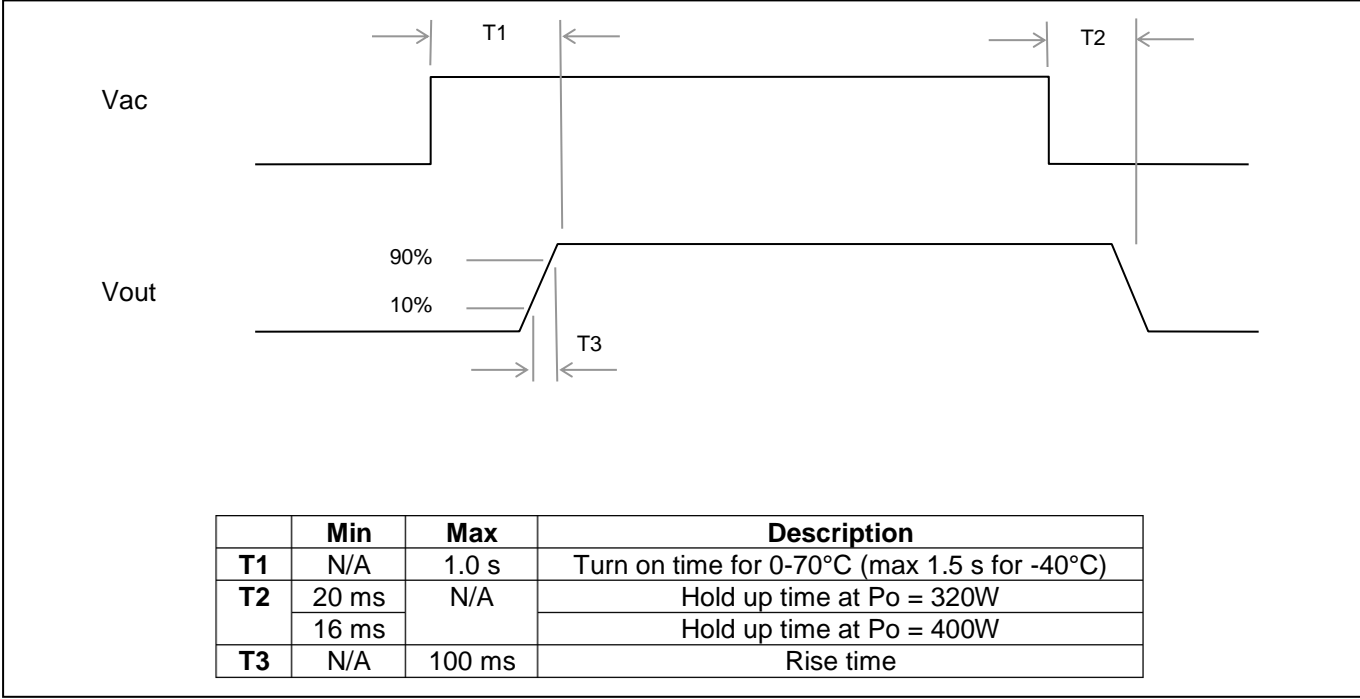

Output timing diagram

The CUS400M incorporates both AC_FAIL and DC_OK signals in the form of independently isolated open-collector outputs. These signals are available on the option board connector, J5. The following information about these signals is relevant for power supplies fitted with an option board.

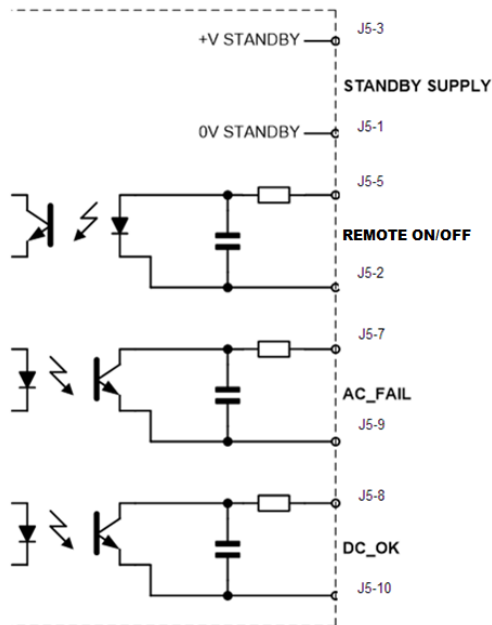

The timing diagrams below show the difference between these signals. It is important to note that the timing of these signals will depend on both AC line input voltage and the output load. Additional external capacitance connected to the main output may also have an effect.

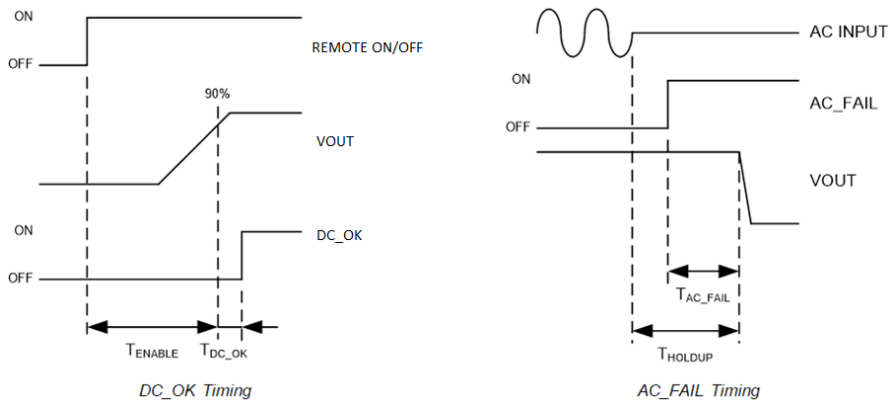

The limiting values for the timing and static parameters are listed below.

Parameter	Min	Max	Comments
T_{ENABLE}	-	150ms	-
T_{DC_OK}	50ms	100ms	-
T_{HOLDUP}	20ms	-	$P_o = 320W$
	16ms		$P_o = 400W$
T_{AC_FAIL}	5ms	-	$P_o > 250W$
	10ms		$P_o \leq 250W$

Parameter	Conditions	Min	Max
Remote On/Off threshold	$I_f = 1mA$	0.8V	2.2V
Output logic low level	$I_c = 10mA$	-	0.4V
DC_OK rising edge threshold	% of V_{out}		95%
DC_OK falling edge threshold	% of V_{out}	70%	

The AC_FAIL and DC_OK signals may be combined with an external pull-down resistor, as shown below, to

produce a single power good (POK) signal.

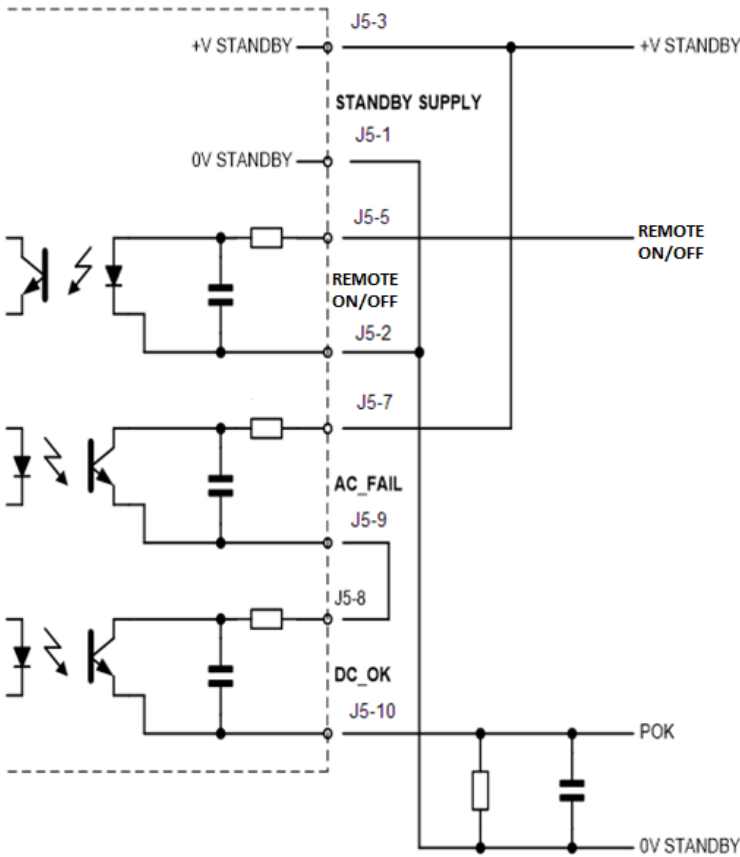

The timing diagram for the combined signal is showed below.

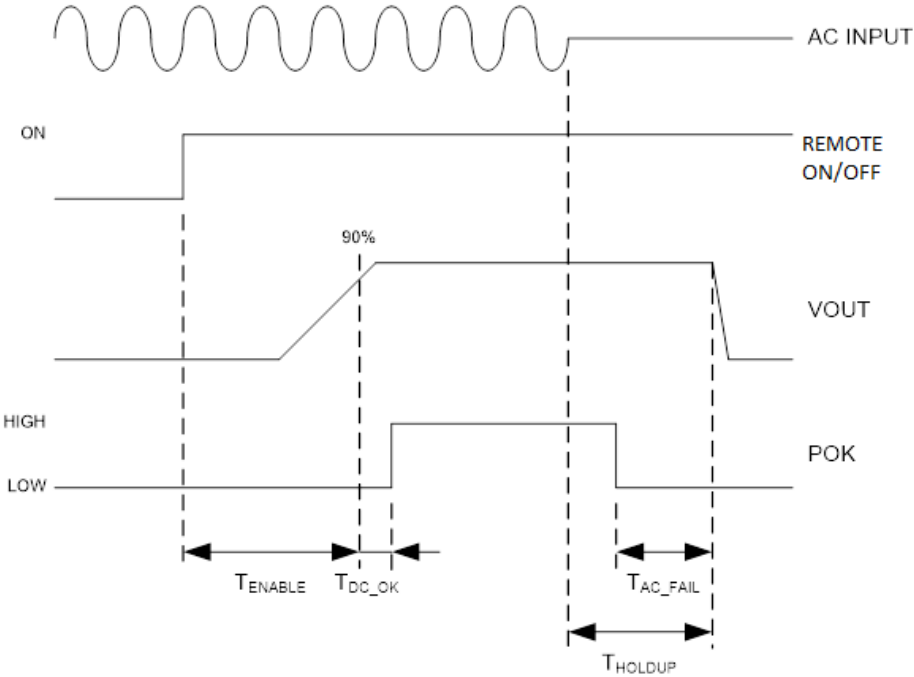

OVERSHOOT AT TURN-ON AND TURN-OFF

The output voltage overshoot upon the application or removal of the input mains voltage shall be less than 10% above the nominal voltage. No opposite polarity voltage is present at any time.

The turn on/off characteristics for the CUS400M at an ambient temperature of 25°C are shown below.

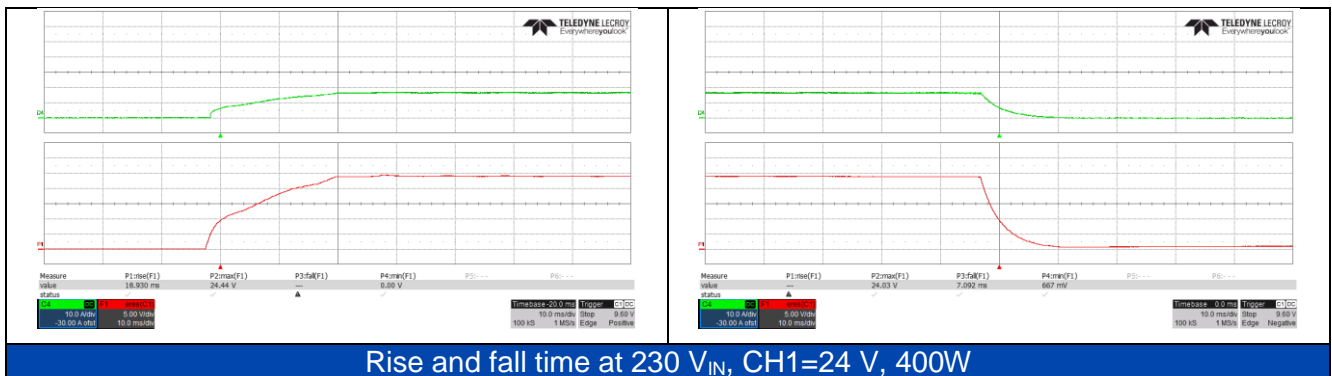
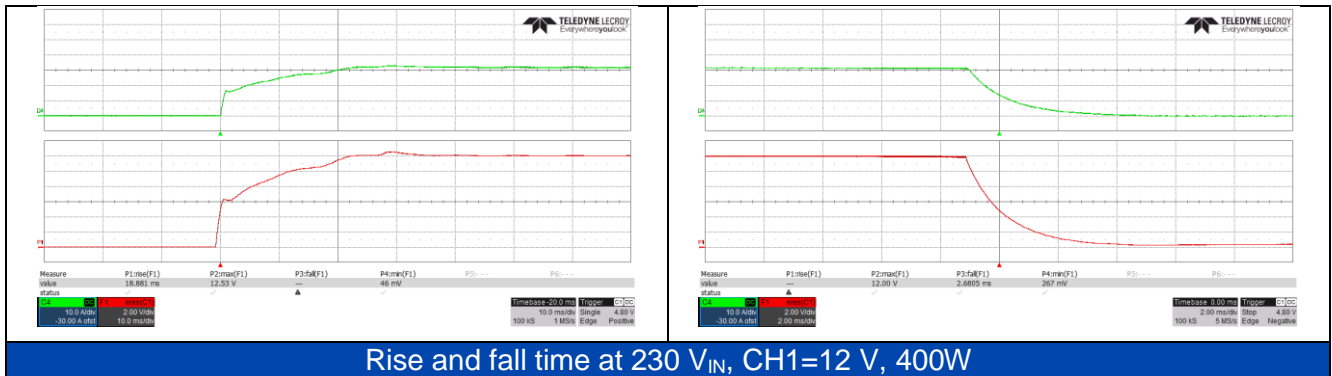

OUTPUT PROTECTION

Overcurrent Protection

If a load is applied such that it puts the power supply in a condition of overcurrent, the power supply will enter a hiccup mode of operation. This will turn the output off for a minimum of 2.0s, and then turn it back on for a maximum of 0.5s. This hiccup mode of operation will continue until the overload is removed.

Short Circuit Protection

A short circuit is defined as an impedance of <0.1 ohms placed between the DC return and any output. A short on the output will cause the power supply to enter a hiccup mode of operation, which offers indefinite protection to the power supply during the duration of the short. While it is not expected to cause any damage to the power supply, it is not recommended to operate the power supply in this condition continuously. In the hiccup mode of operation, the power supply will attempt to restart until the short on the output is removed. After the short has been removed, the power supply will resume normal operation.

Over-temperature Protection

The power supply is designed to operate without any damage below the minimum input, including at full power. If the CUS400M power supply is operated outside of recommended operating conditions, an over-temperature condition may result. This will cause the power supply to latch off. Over-temperature protection has been incorporated in both the primary and secondary sections of the power supply. In addition to this, some components have in-built over temperature protection. In the eventuality of the power supply shutting down because of over-temperature, the AC supply needs to be removed and reapplied after a minimum duration of 60 seconds to resume normal operation.

Overvoltage Protection

An overvoltage on the output will cause the power supply to latch off. To restart the unit, the AC supply needs to be removed and reapplied after a minimum duration of 60 seconds. The overvoltage threshold is 115–140% of the standard output voltage for each model and does not alter when output voltage is adjusted.

5. COOLING REQUIREMENTS

The maximum continuous ratings and power derating of the power supply for high ambient temperatures are specified in the datasheet (model dependent).

Please refer to the CUS400M handbook for a list of components that are to be monitored thermally to ensure safe and reliable operation.

CONVECTION AND CONDUCTION COOLING

Based on different orientations of the power supply (relevant to both the open frame and chassis options), it is recommended to operate the CUS400M with the top side of its leaded components facing up in order to achieve optimal thermal performance. It is important to note that this recommendation is only for information and the actual performance may vary in end user application due to surrounding objects and convection airflow around the power supply.

The different configurations of the CUS400M power supply along with their thermal performance characteristics are shown. Conduction cooling in the characteristics shown below refers to the power supply mounted on a 300 x 300 x 1 mm aluminium plate.

EXAMPLE CURVES

The curves below are guidelines only. The actual performance should be tested in the application.

Open Frame

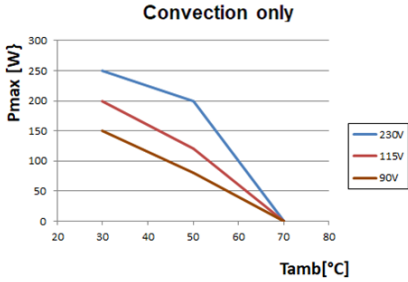
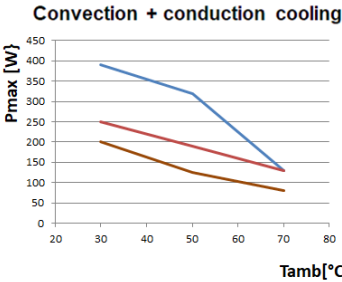
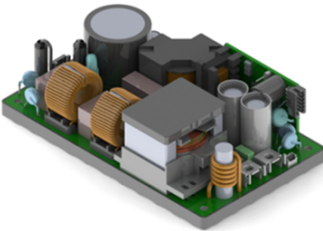

/B Baseplate

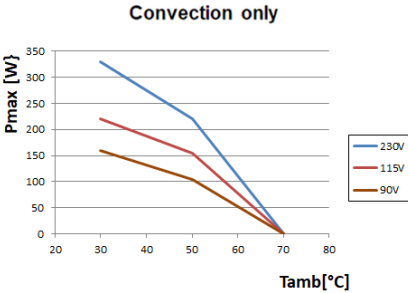
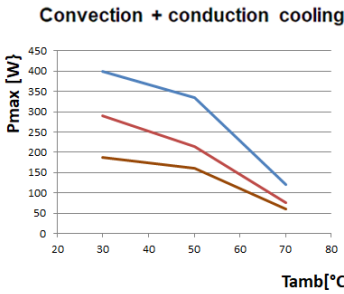
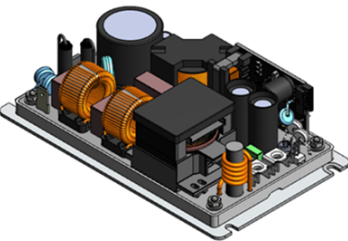

/U U-chassis

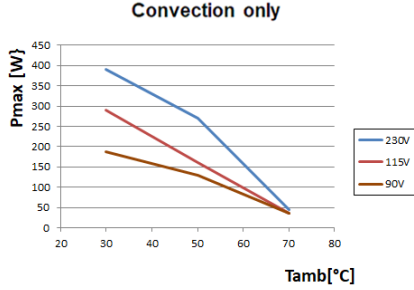
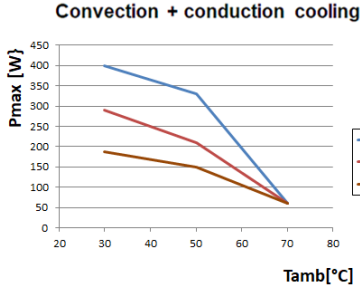
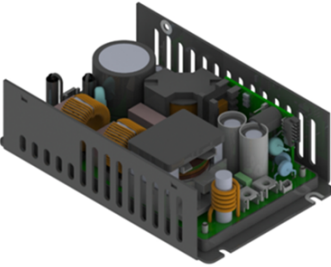

/A Top Cover

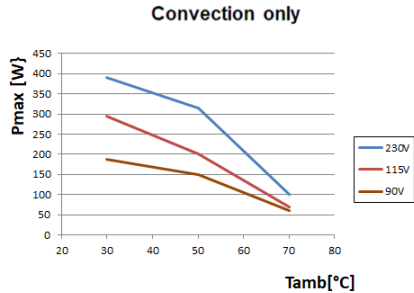
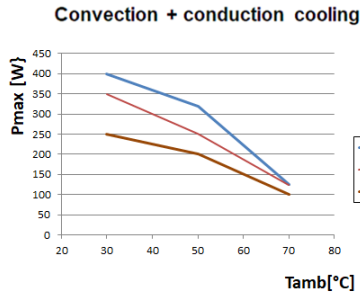

The peak power performance of the CUS400M fitted with a U-chassis (/U configuration) and employing both convection and conduction cooling is shown:

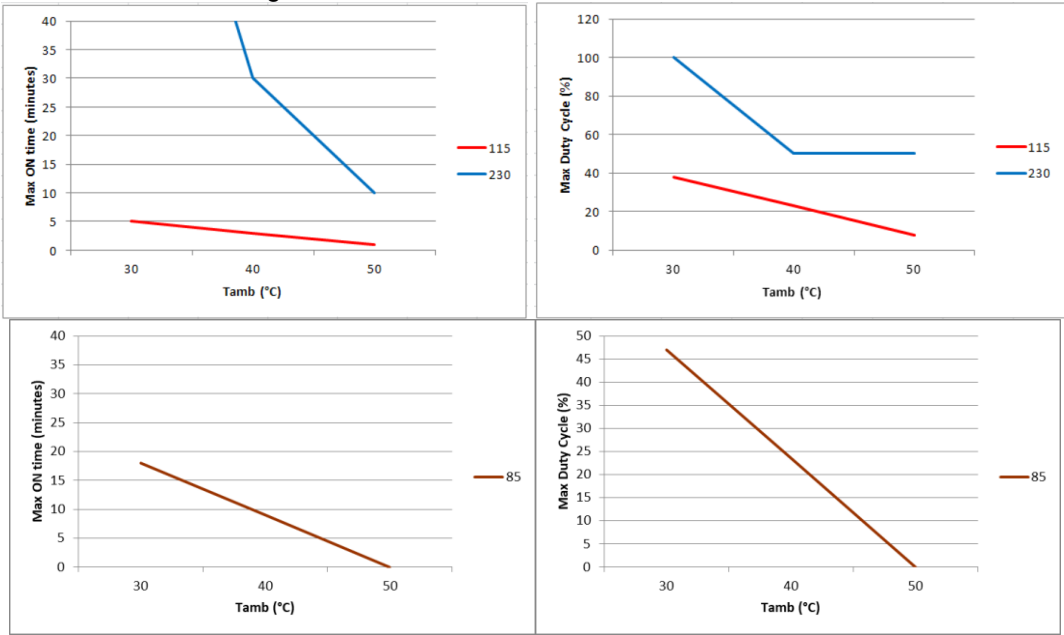

Maximum achievable output power at different temperatures and AC line input conditions is summarised in this table.

Ambient temperature [°C]	AC line input [Vrms]	Maximum ON time [minutes]	Maximum duty cycle [%]	Maximum achievable output power
30	85	18	47	250W peak
	115	5	38	400W peak
	230	∞	100	400W continuous
40	230	30	50	400W peak
50	85	0	0	No peak rating
	115	1	8	400W peak

	230	10	50	400W peak
--	-----	----	----	-----------

FORCED AIR COOLING

Enhanced thermal performance is achieved with an external fan in comparison with convection cooling. For power supply units without an internal fan, airflow is recommended to be directed from the input towards the output. The amount of airflow required depends upon the applied input voltage, airflow direction, output power and position of the power supply in the end application. Consult technical sales for more details.

The thermal performance of the CUS400M power supply with a top fan (/F configuration) is shown below. It is possible to achieve 400 W of output power at 230 VAC line input for ambient temperatures up to 30°C to 50°C.

/F Top Fan

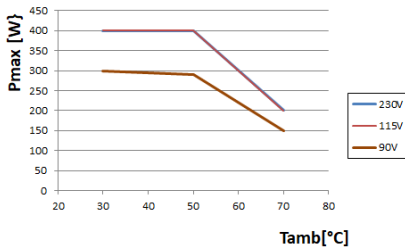
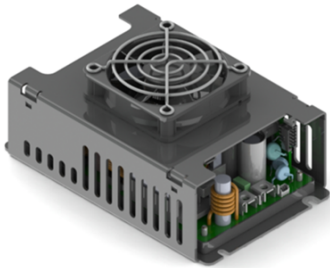

6. RELIABILITY

Reliability is calculated according to Telcordia SR332 Issue 4, Method I-D (Black box), Ground, fixed, controlled, at 30°C.

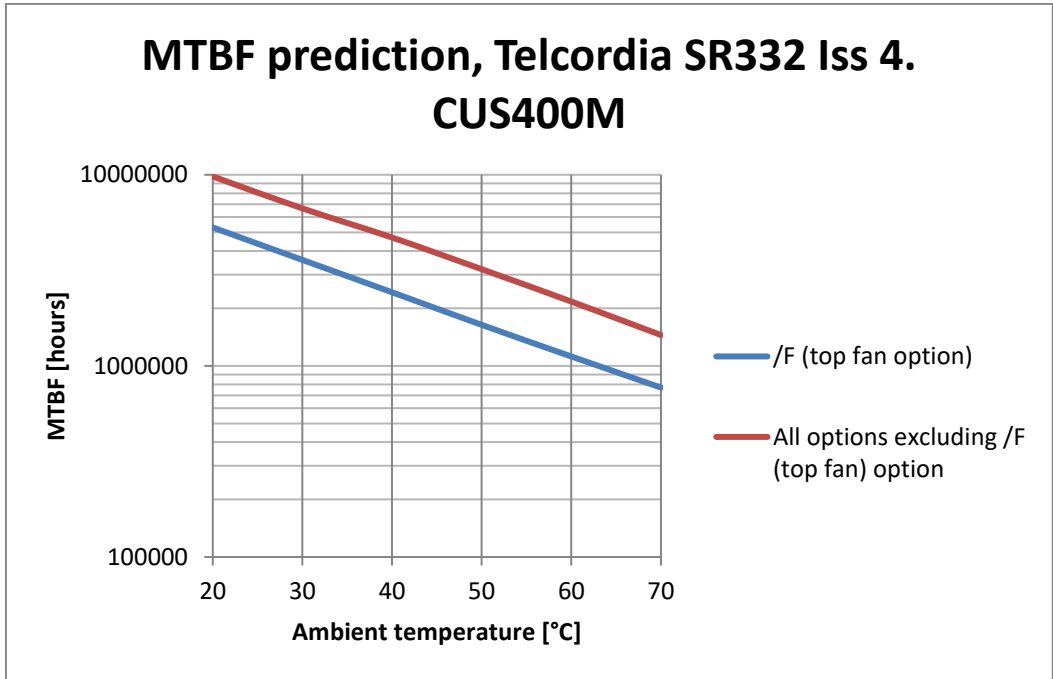

ELECTROLYTIC CAPACITOR LIFETIMES

This set of curves helps in determining capacitor life based on continuous (i.e. 24 x 7) operation. Actual temperature values should be measured in the end application as they depend upon the mounting orientation, ambient temperature and the type of cooling method involved. The manufacturer prescribed maximum operating temperature for all of these aluminium electrolytic capacitors is 105°C.

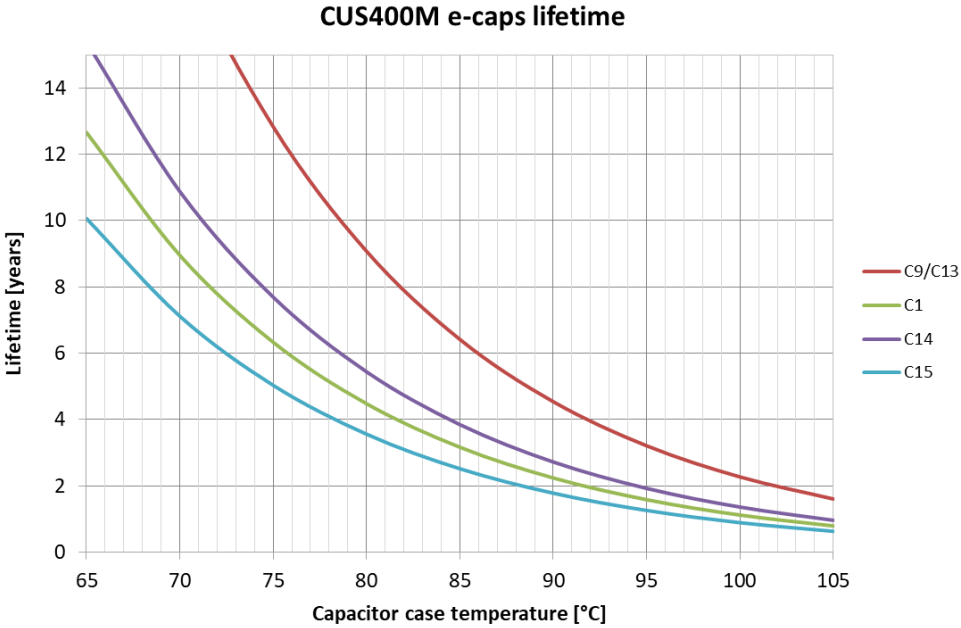

Example life curves for a convection cooled CUS400M-12 are presented below:

Conditions Ta 20°C - 50°C
 Line 115V & 230V
 Load 250W

Convection Cooled, mounted on 50mm standoffs

E-Cap life (Years) 115Vac Convection Cooled				
Load (%)	Tamb (°C)			
	20	30	40	50
25%	15	15	15	9.12
50%	15	15	9.11	4.56
75%	15	8.99	4.49	2.25
100%	9.11	4.56	2.28	1.14

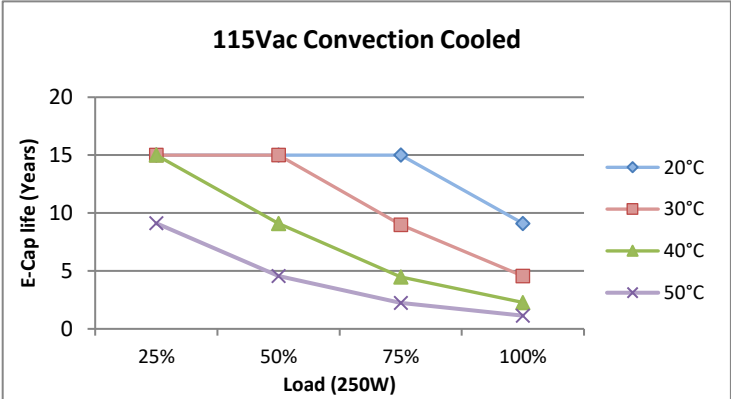

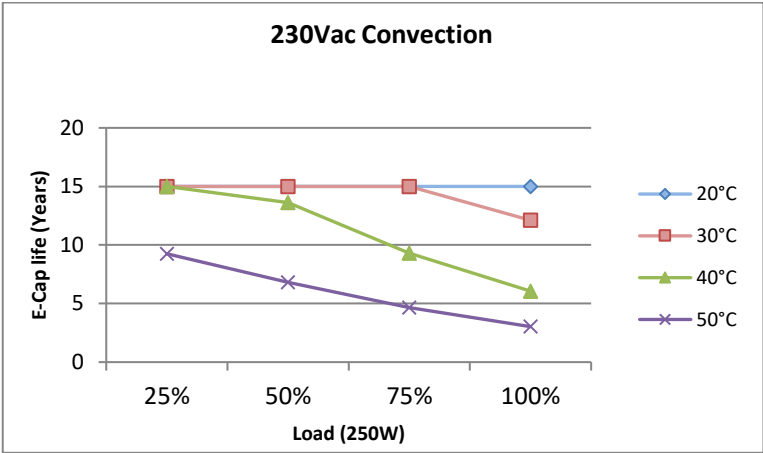

E-Cap life (Years) 230Vac Convection Cooled

Load (%)	Tamb (°C)			
	20	30	40	50
25%	15	15	15	9.25
50%	15	15	13.63	6.82
75%	15	15	9.31	4.66
100%	15	12.11	6.06	3.03

Convection & Conduction Cooled
 Mounted on 300x300x0.8mm Aluminium sheet

E-Cap life (Years) 115Vac Convection + Conduction				
Load (%)	Tamb (°C)			
	20	30	40	50
25%	15	15	15	10.79
50%	15	15	11.54	7.11
75%	15	12.29	6.14	3.07
100%	15	6.69	3.35	1.67

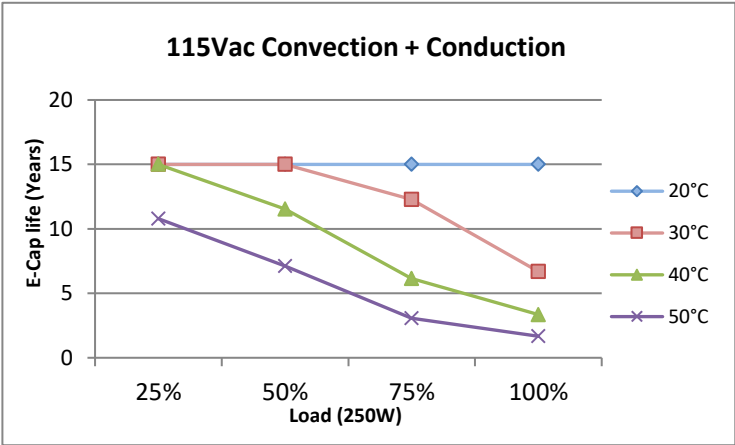

E-Cap life (Years) 230Vac Convection + Conduction				
Load (%)	Tamb (°C)			
	20	30	40	50
25%	15	15	15	11.18
50%	15	15	15	8.57
75%	15	15	12.57	6.29
100%	15	15	8.39	4.19

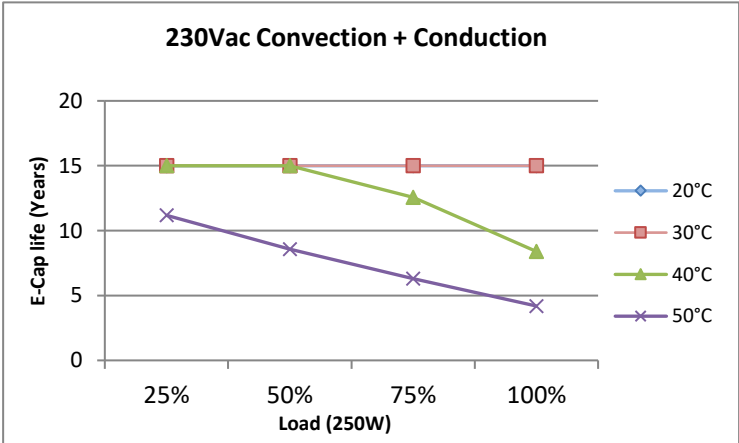

Note :

E-cap life calculation is based on 24hrs/day operation.
 e.g. For 12Hrs/day operation life numbers will double

The lifetime is calculated based on our method and doesn't include the seal rubber degradation effect etc

7. ELECTROMAGNETIC COMPATIBILITY

For full details of EMC performance, see 260607 - CUS400M Electromagnetic Compatibility Report.

Example Conducted Emissions result for the CUS400M at 115VAC, 400W, Class I (/F configuration)

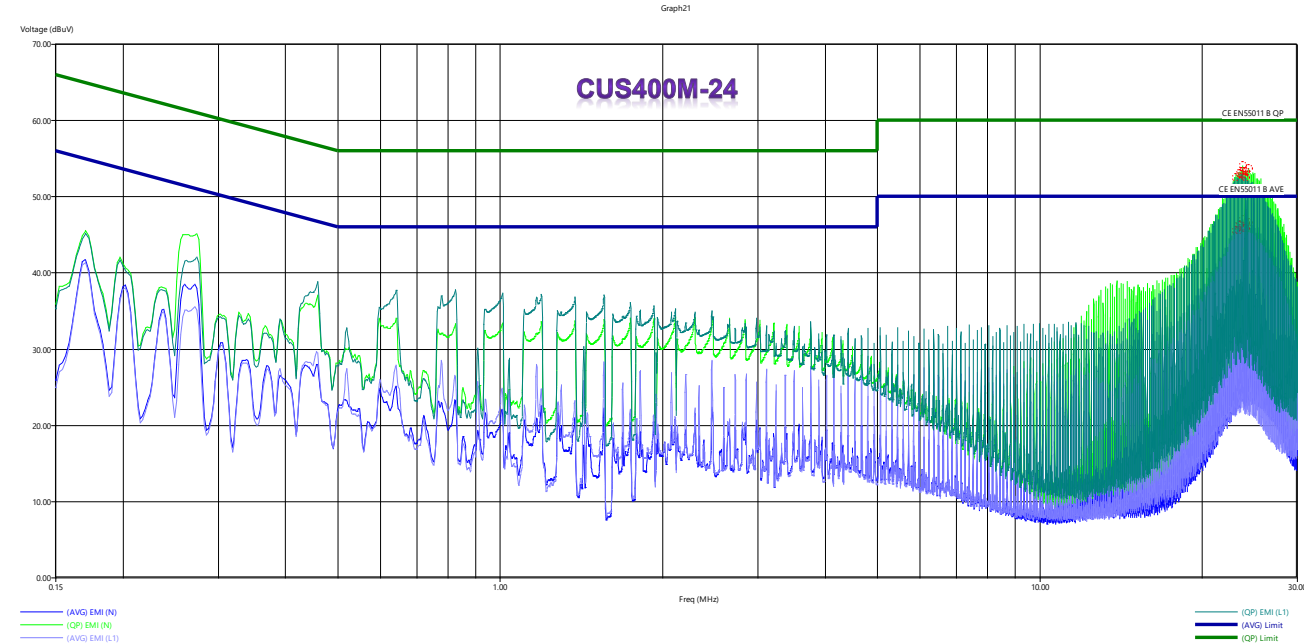
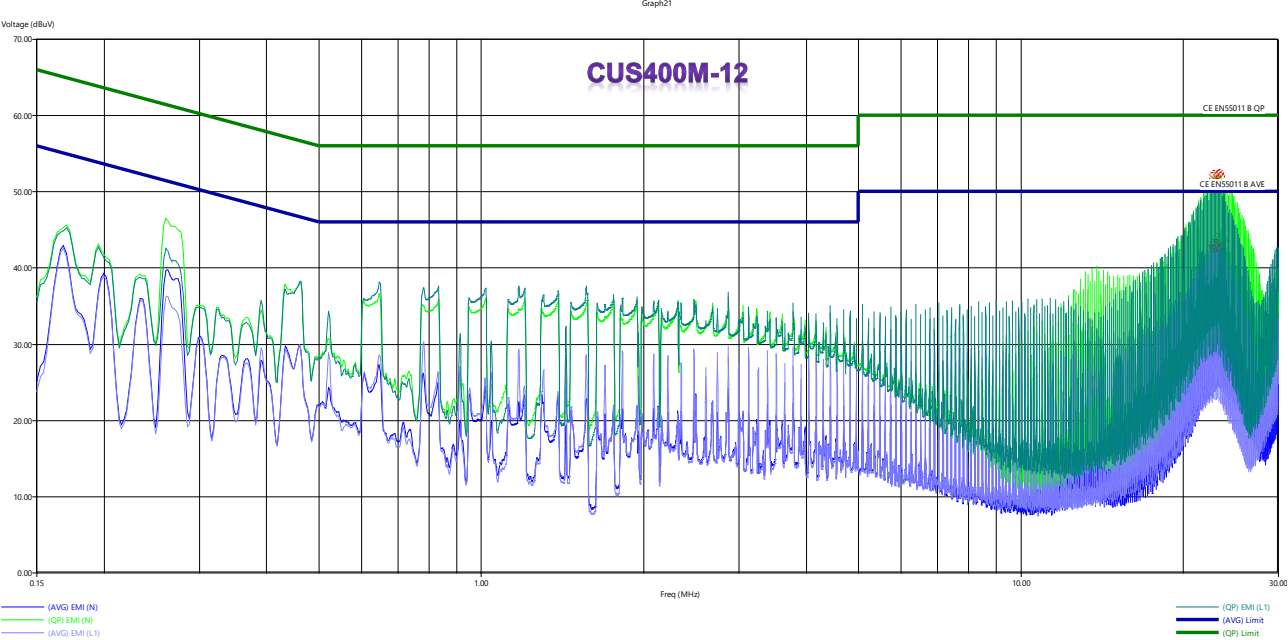

Example Conducted Emissions result for the CUS400M at 230VAC, 400W, Class II (/F configuration)

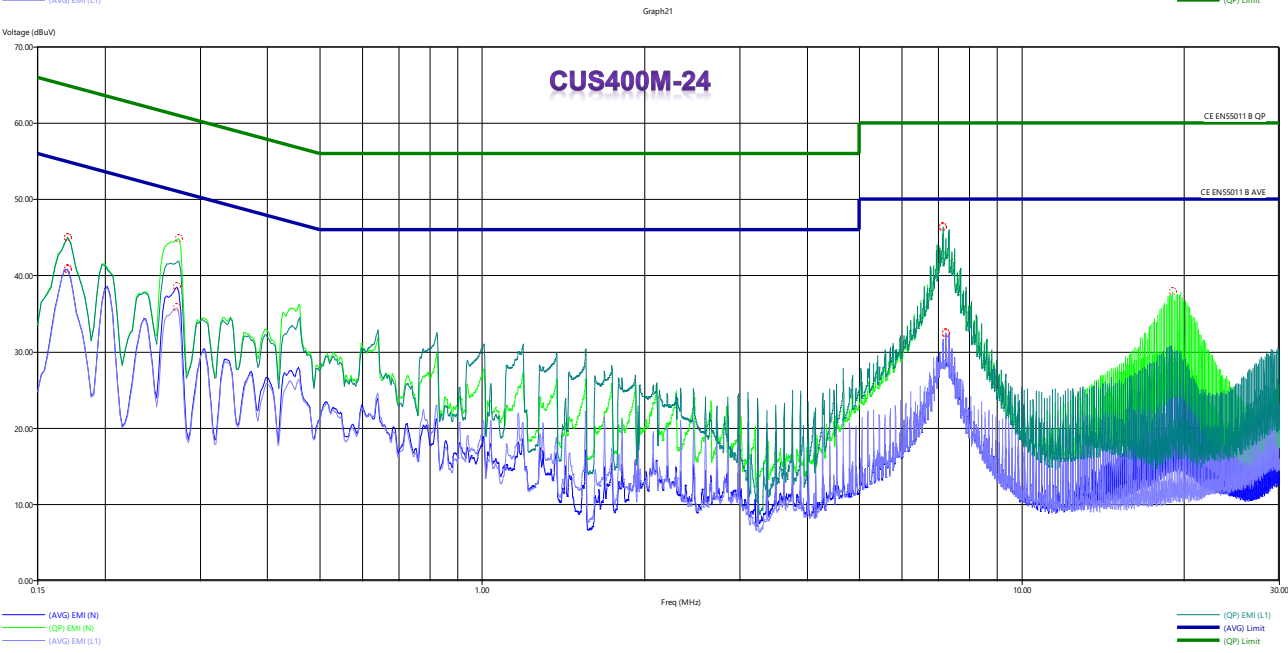
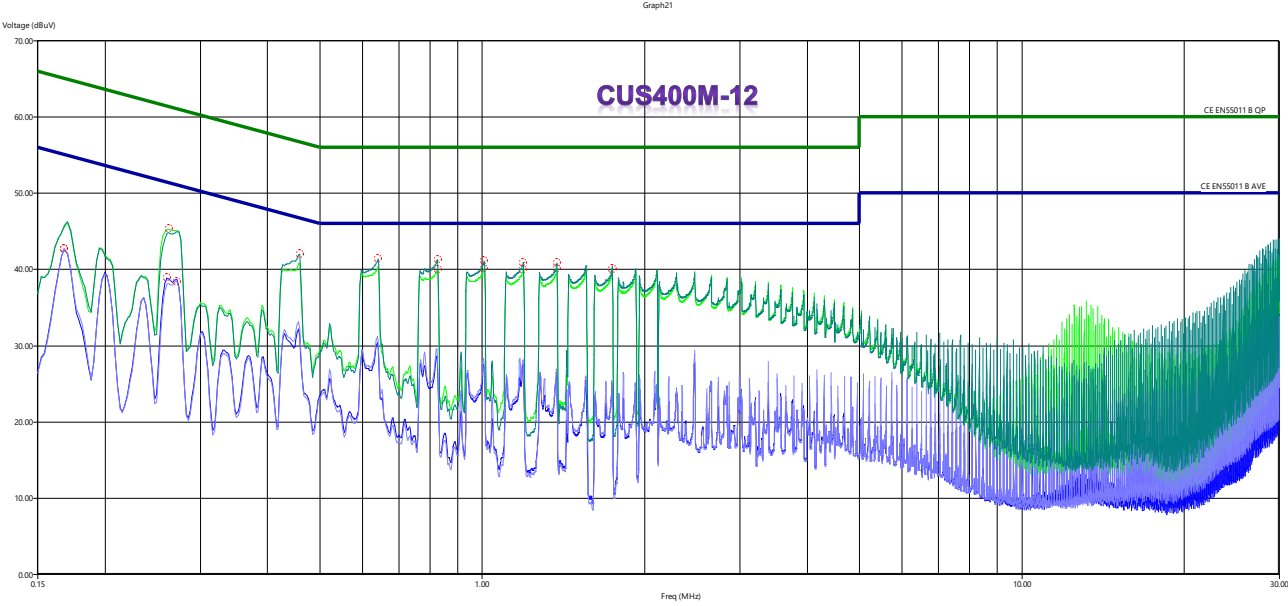

Example Radiated Emissions result for the CUS400M at 230VAC, 400W, Class I (/F configuration)

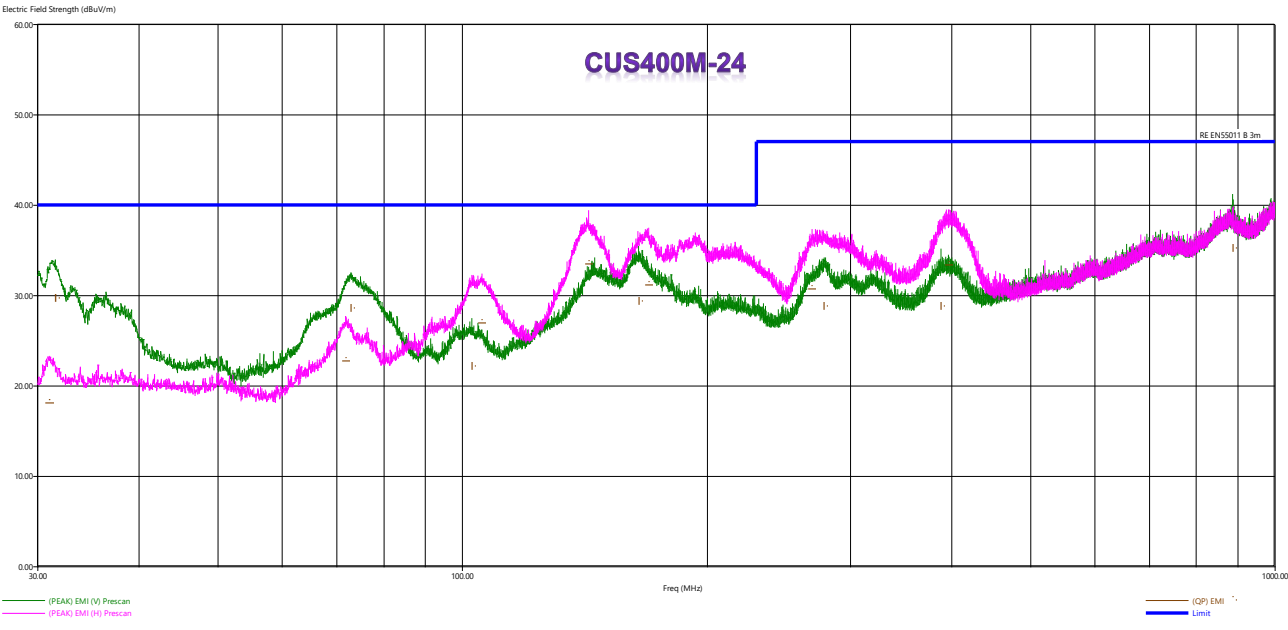
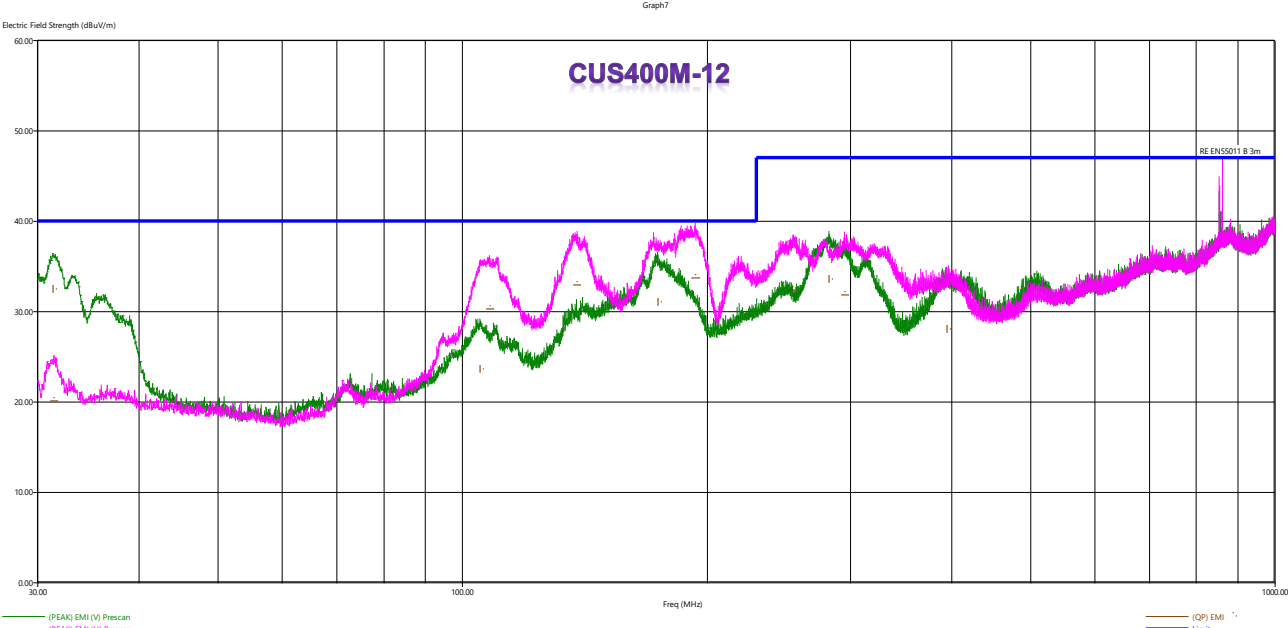

Example Radiated Emissions result for the CUS400M at 115VAC, 400W, Class II (/F configuration) FCC Limits

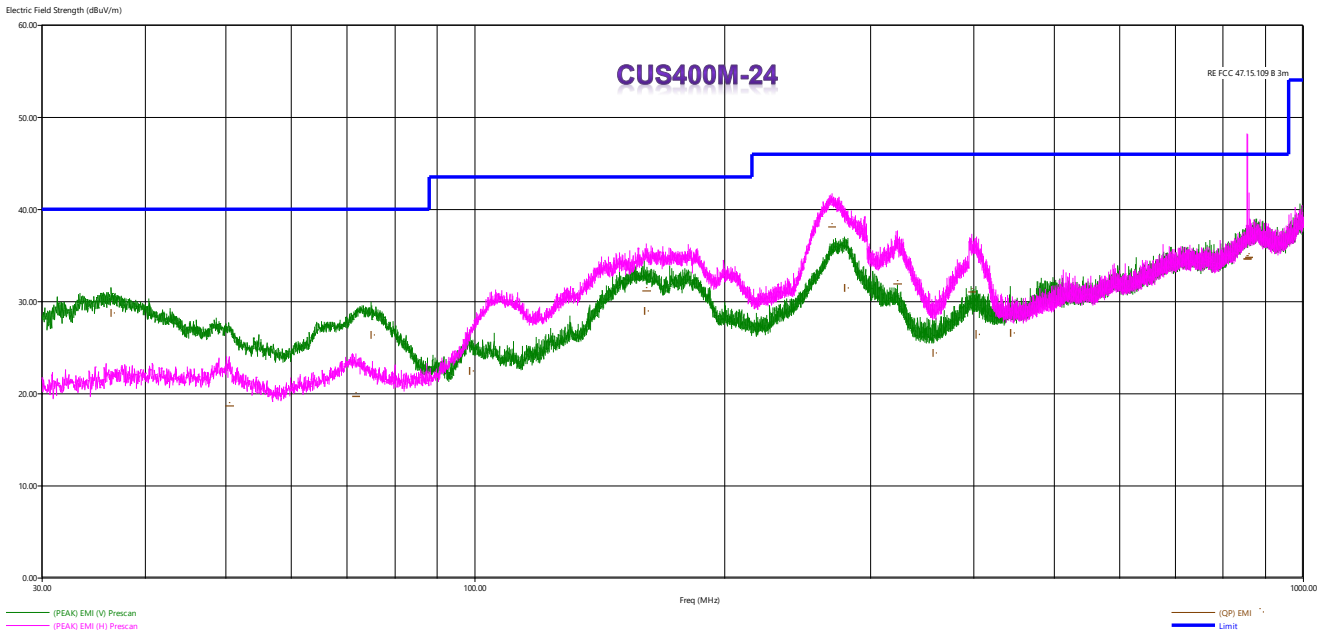
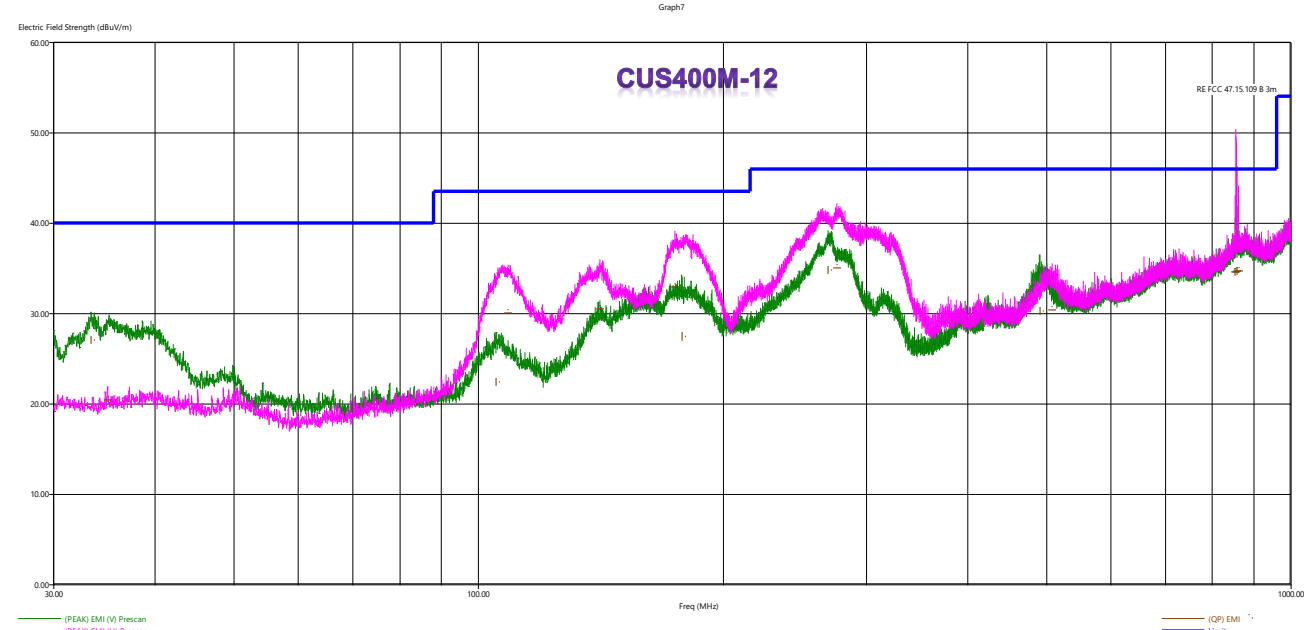

INSTALLATION FOR OPTIMUM EMC PERFORMANCE

Mounting

All equipment should, ideally, be mounted inside an earthed, shielded metal box. Alternatively, an earthed metal plate can be used to mount the power supply and load. All four mounting holes (one in each corner) of the CUS400M should be utilised for best electrical and mechanical performance.

If required, the CUS400M can be operated as a Class II power supply (without an earth connection). For optimal EMC performance on Class II installations using the open frame model, the Power supply's Y-caps should be electrically connected externally, via the connection of the mounting holes (e.g. through a metal baseplate/chassis or suitable wiring).

The radiated and conducted emissions of CUS400M were tested with a 3 x 5 inches baseplate under the power supply to achieve Class B limits (the baseplate simulates a metal chassis).

The following can further improve system level EMC performance (dependent on the actual application and installation)

- Adding a ferrite clamp such as TDK ZCAT2235-1030 on to input cable, output cable, option cable or all.
- Adding an external mains input filter such as EPCOS filter B84773M0006A000

Cables

All cables (both AC input and DC output) should be run as close as possible to the earthed metal box/plane. AC input cable should be a twisted group laid as flat as possible to the earthed metal box/plane.

All output cables should be routed as far away from the input cables as possible. If the input and output cables must run close to each other, it is recommended to screen one of them (or ideally both).

The positive and negative supply cables should be twisted together.

All cable run loops should be kept as small as possible (this should be implemented in the system PCB design as well).

Run the remote sense (if used) and power output cables as separate pairs twisted tightly together with at least 1 twist per centimetre.

Earth Star Point

Where the AC supply enters the equipment, this should be taken to a 'star point' chassis mounted earth point as close as possible to the mains inlet. All other earth points should be taken back to this point only.

ESD Protection

Where signal or control ports are connected to a user accessible panel (for example PSU inhibit to a switch, module good to an indicator circuit, etc), these ports must be protected from electrostatic discharges. This can be done by selecting suitable panel controls or by fitting ESD suppression devices to the connections on the panel.

Switching Frequency

The CUS400M has a variable switching frequency ranging from 45 kHz to 180 kHz, depending upon the input voltage, output voltage and output load.

8. MECHANICAL

Weight

Maximum weights for different configurations of the CUS400M power supply are listed.

Configuration	Weight
Open frame (I)	440 g
/B (with metal baseplate)	495 g
/C (with M3 threaded inserts for underside mounting)	445 g
/U (with U-chassis)	530 g
/A (with U-chassis and cover)	550 g
/F (with U-chassis and top fan)	605 g

Outline Drawings

Open Frame version

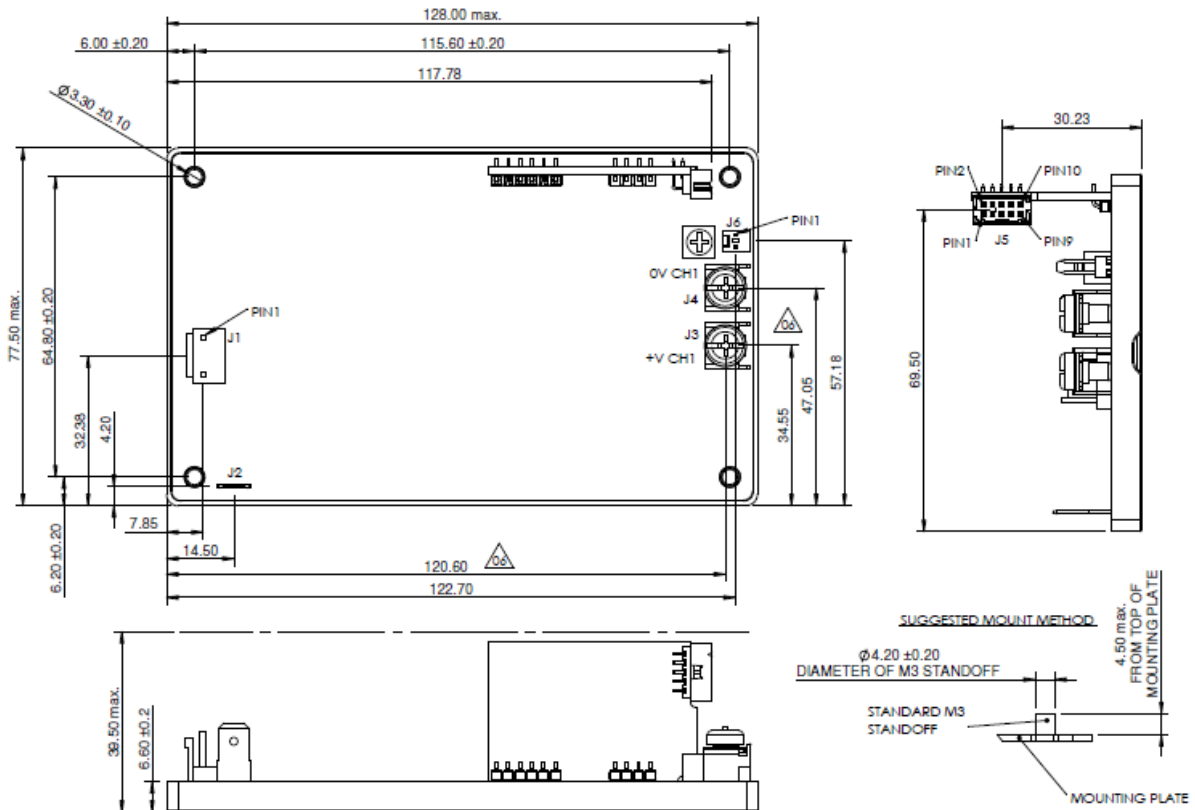

CONNECTORS

CONNECTOR	MANUFACTURER	HOUSING	CRIMP PIN
J1	JST	VAR-2	SVA-41T-P1.1
J2	TYCO	N/A	2-520407-2
J3 & J4	MOLEX	N/A	TAG 19073-0165
J5	MOLEX	51110-1051	50394
J6	MOLEX	51191-0200	50802

J1

PIN	CONNECTION
1	NEUTRAL
2	NOT CONNECTED
3	LIVE

J2 - EARTH

J3	+V CH1
J4	0V CH1

NOTE:

- (1). '0V STANDBY' AND '0V CH1' ARE ISOLATED
 (2). '0V FAN' AND '0V CH1' ARE INTERNALLY CONNECTED

J6

PIN	CONNECTION
1	+V FAN
2	0V FAN (2)

J5 OPTION ONLY

PIN	CONNECTION
1	0V STANDBY (1)
2	REMOTE ON/OFF -
3	+V STANDBY
4	+ SENSE
5	REMOTE ON/OFF +
6	- SENSE
7	AC FAIL-COLLECTOR
8	DC OK COLLECTOR
9	AC FAIL-EMITTER
10	DC OK EMITTER

With baseplate /B

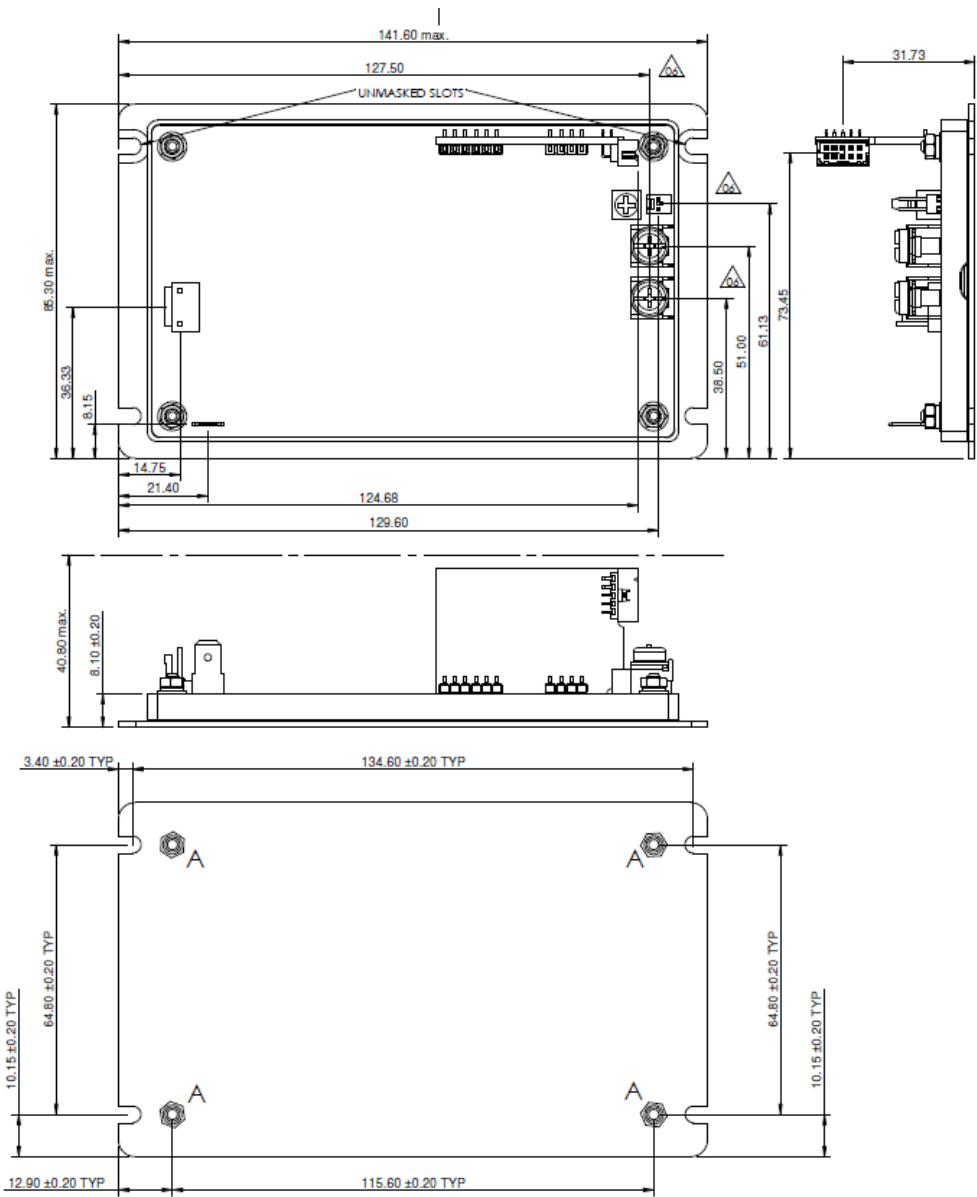

With U channel /U

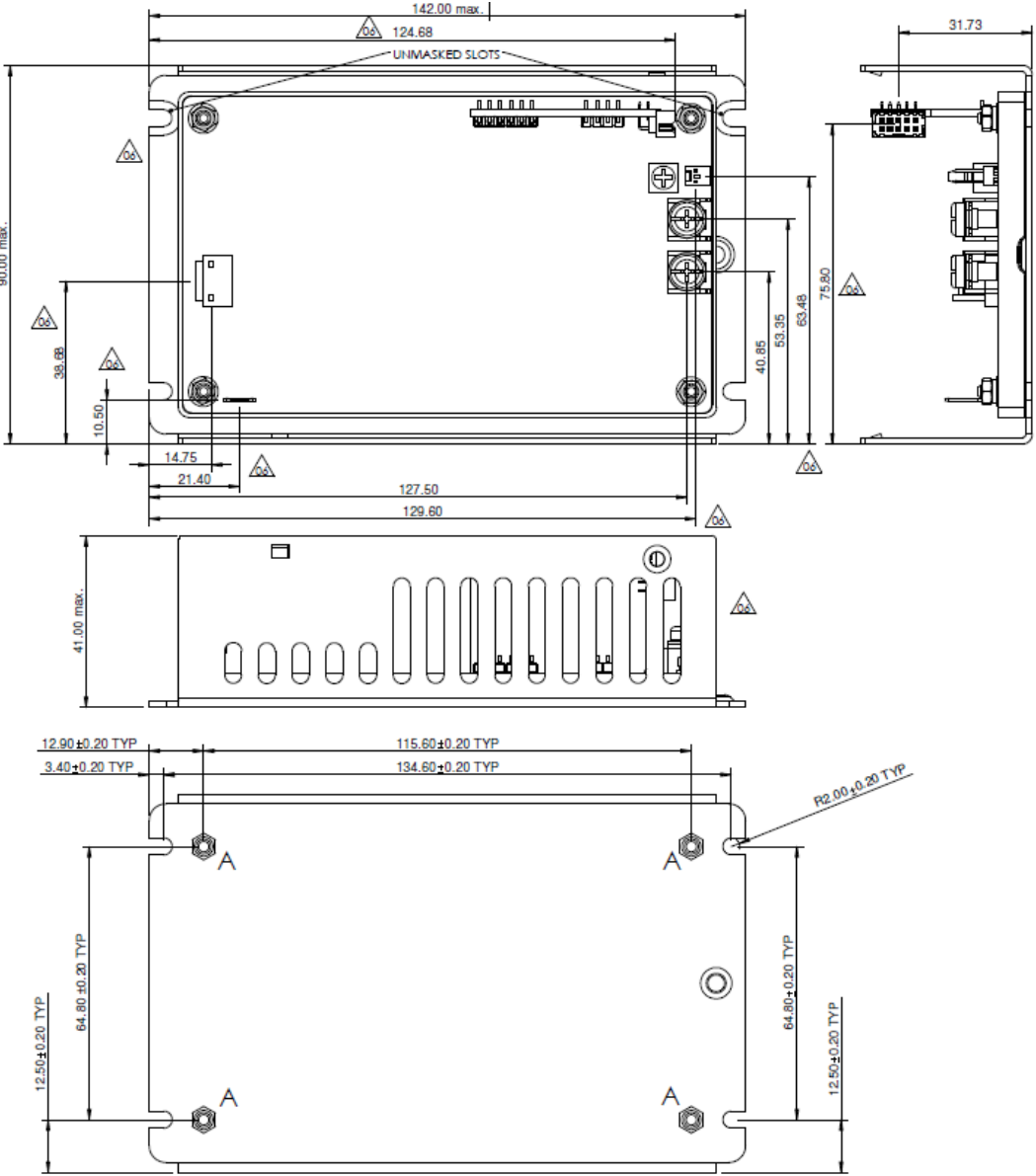

With U channel and cover /A

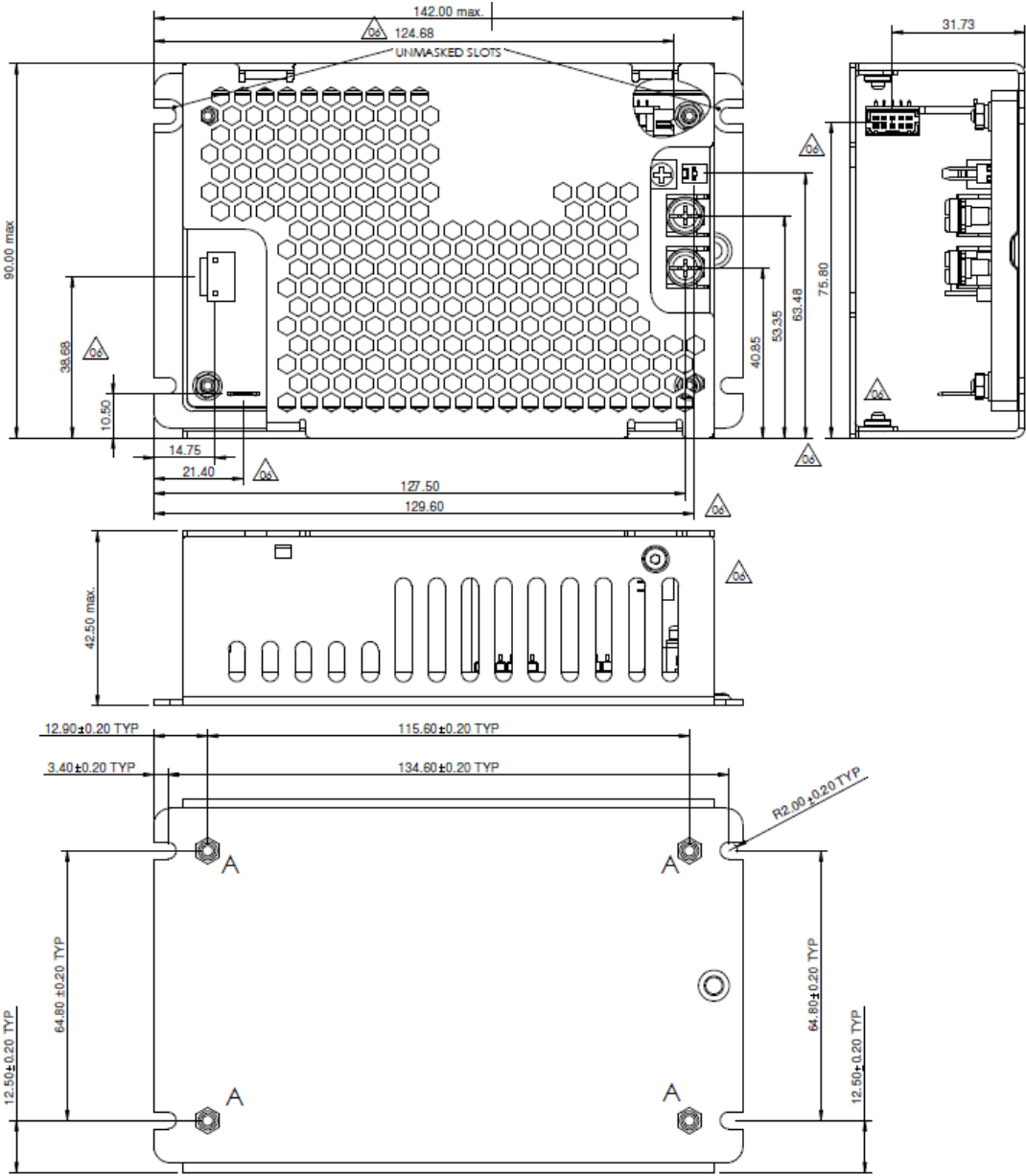

With top mounted fan /F

