

OR50 – 50A Universal Active ORing Controller

■ **Main Features:**





- Ultra Compact Redundancy Module
- CPU controlled
- Wide input voltage range 12...85Vdc (on a single model)
- 50A Max
- Extremely low loss up to 99% efficiency
- Pluggable connectors
- Hot pluggable
- Easy acknowledgment of the power supplies availability status
- Easy correct current share status
- Up to 75°C operating temperature with no derating



INDEX	
Installation Requirements	Page 2
Declaration of Conformity	2
User Instructions	3
Connections	3
Dimensions	3
Distances	3
Mounting	4
Dismounting	4
Recommended Connecting Cable	4
Input Protection	5
I/O Connections	5
Environment	5
Note	5

READ THIS CAREFULLY BEFORE INSTALLATION!	VOR DER INSTALLATION BITTE FOLGENDE SICHERHEITSHINWEISE BEACHTEN	LEGGERE ATTENTAMENTE PRIMA DELL'INSTALLAZIONE!	A LIRE ATTENTIVEMENT AVANT L'INSTALLATION!
<p>Before operating, read this document thoroughly and retain it for future reference. Non-respect of these instructions may reduce performances and safety of the devices and cause danger for people and property. The products must be installed, operated, serviced and maintained by qualified personnel in compliance with applicable standards and regulations. Don't open the device, it does not contain replaceable components, the tripping of the internal fuse (if included) is caused by an internal failure. Don't repair or modify the device, if malfunction or failure should occur during operation, send unit to the factory for inspection. TDK-Lambda Switzerland SA assumes no responsibility for any consequences deriving from the use of this material.</p>	<p>Lesen Sie dieses Dokument vor der Inbetriebnahme sorgfältig durch und bewahren Sie es zum späteren Nachschlagen auf. Die Nichtbeachtung dieser Anweisungen kann die Funktion und Sicherheit der Geräte beeinträchtigen und birgt Gefahren für Personen und Eigentum. Die Geräte müssen von qualifiziertem Personal unter Einhaltung der geltenden Normen und Vorschriften installiert, betrieben, gewartet und instand gehalten werden. Öffnen Sie das Gerät nicht, es enthält keine austauschbaren Komponenten, das Auslösen der internen Sicherung (falls vorhanden) ist stets auf tiefergehende Fehler im Schaltkreis zurück zu führen. Reparieren oder modifizieren Sie das Gerät nicht. Sollte während des Betriebs eine Fehlfunktion oder ein Defekt auftreten, schicken Sie das Gerät zur Überprüfung ins Werk. TDK-Lambda Switzerland SA übernimmt keine Haftung für die Folgen, die sich aus dem Einsatz dieses Gerätes ergeben.</p>	<p>Prima dell'installazione, leggere attentamente questo documento istruzioni e conservarle per future consultazioni. L'inosservanza delle presenti istruzioni può compromettere le caratteristiche e la sicurezza dell'apparecchio e causare pericolo per le persone e le cose. Il prodotto deve essere installato, utilizzato e riparato da personale qualificato e nel rispetto delle normative vigenti. Non aprire il prodotto, esso non contiene componenti sostituibili, il guasto del fusibile interno (se previsto) è causato da un guasto interno. Non tentare di riparare o modificare il prodotto, se durante il funzionamento si verificano guasti o anomalie, inviarlo al produttore per il controllo. TDK-Lambda Switzerland SA non si assume nessuna responsabilità per qualunque conseguenza derivante dall'uso di questo materiale.</p>	<p>Lisez ces instructions avant l'installation, conservez ce manuel pour référence future. Défaut de se conformer à ces instructions peut affecter les caractéristiques et la sécurité du dispositif de danger et de causer aux personnes ou aux biens. Les produits doivent être installés, exploités et entretenus par personnel qualifié et en conformité avec les règlements. N'ouvrez pas le produit, il ne contient aucune pièce réparable, le déclenchement du fusible interne (le cas échéant) est causé par un défaut interne. Ne pas essayer de réparer ou modifier le produit ; si des défaillances se produisent pendant le fonctionnement ou les dysfonctionnements, le retourner au fabricant pour inspection. TDK-Lambda Switzerland SA n'assume aucune responsabilité des conséquences éventuelles découlant de l'utilisation des produits.</p>
CAUTION	ACHTUNG	ATTENZIONE	AVVERTISSEMENT
<p>RISK OF BURNS, EXPLOSION, FIRE, ELECTRICAL SHOCK, PERSONAL INJURY. Never carry out work on live parts! Danger of fatal injury! The product's enclosure may be hot, allow time for cooling product before touching it. Do not allow liquids or foreign objects to enter into the products. To avoid sparks, do not connect or disconnect the device before having previously turned-off input power and wait for internal capacitors discharge (minimum 1 minute).</p>	<p>GEFAHR VON VERBRENNUNGEN, EXPLOSIONEN, FEUER, STROMSCHLAG, PERSONENSCHÄDEN. Führen Sie niemals Arbeiten an spannungsführenden Teilen durch! Gefahr von tödlichen Verletzungen! Das Gehäuse des Gerätes kann heiß sein, lassen Sie Zeit zum Abkühlen des Gerätes, bevor Sie es berühren. Lassen Sie keine Flüssigkeiten oder Fremdkörper in die Geräte eindringen. Um Überschläge zu vermeiden, schließen Sie das Gerät nicht an oder trennen Sie es nicht ohne vorher die Eingangsspannung abgeschaltet zu haben, und warten Sie die Entladung der internen Kondensatoren ab (mindestens 1 Minute).</p>	<p>RISCHIO USTIONI, ESPLOSIONE, INCENDIO, SCOSSA, LESIONI GRAVI. Non effettuare mai operazioni sulle parti sotto tensione! Pericolo di lesioni letali! Il contenitore può scottare, lasciar quindi raffreddare il dispositivo prima di toccarlo. Non far entrare liquidi o oggetti estranei nel dispositivo. Per evitare scintille, non collegare o scollegare l'apparecchiatura prima di avere tolto tensione di ingresso e prima che sia avvenuta la scarica dei condensatori interni (min. 1 minuto).</p>	<p>RISQUE DE BRULURES, EXPLOSION, INCENDIE, ELECTROCUTION, DOMMAGE AUX PERSONNES. Ne jamais effectuer des opérations sur les parties sous tension! Danger de mort! Le récipient peut produire des brulures, le laisser refroidir avant de toucher l'appareil. Ne faites pas pénétrer des liquides ou des corps étrangers dans l'appareil. Pour éviter des étincelles, ne pas connecter ou déconnecter l'équipement jusqu'à ce que vous avez supprimé la tension d'entrée et avant qu'elle n'ait lieu de décharge des condensateurs internes (minimum 1 minute).</p>

DECLARATION OF CONFORMITY

					TDK-LAMBDA SWITZERLAND SA Via Luserte Sud 6, 6572 Quartino - Switzerland Phone: +41-(0)91 840 14 46 / 840 14 48; Fax: +41-(0)91 840 14 47 E-mail: TLN.info@tdk.com						
This Declaration of Conformity is suitable to the European Standard EN45014 "General criteria for supplier's declaration of conformity". We declare under our sole responsibility that the device included in this box, has passed all processing inspections and the final test and it is in conformity with the product requirements, including all reference codes and supply specifications.											
ROHS compliance: the product respects the EC requirements related to ROHS substances, according to "Restriction of Hazardous Substances" as per document 2011/65/UE REACH compliance: the product respects the EC requirements related to REACH SVHC directive (EC) 1907/2006 Note: all the reported information comes from our suppliers, TDK-LAMBDA SWITZERLAND SA has not run any test to evaluate if the specific elements are present.											
All indicated devices are designed according to the latest Reference standards, if not expressly indicated through the official documents or files, they have been tested through our internal pre-compliance testing. Consult directly on www.nextys.com the reference standards applied to each model.											
Code		Description									
OR50		50A Universal Active ORing Controller 12...85Vdc									
Certifications and approvals											
Reference standards		2014/35/EU (2014) 2014/30/EU (2014) EN61010-1 EN61010-2-201 UL508 EN61000-6-2:2005 - EN61000-4-2:2008 - EN61000-4-3:2006 /A2:2010 - EN61000-4-4:2012 - EN61000-4-5:2014 - EN61000-4-11:2004 /A1:2010 EN61000-6-4:2007 /A1:2011 - EN55022:2010 - EN55011:2009 /A1:2010		(Low Voltage Directive) (EMC directive) (Safety Standard) (Safety Standard) (Certified - IND. CONT. EQ. 4WX9 file no. E356563) (Generic immunity standard for industrial environments) (Electrostatic discharge immunity test) (Radiated, radio-frequency, electromagnetic field immunity test) (Electrical fast transient/burst immunity test) (Surge immunity test) (Voltage dips, short interruptions and voltage immunity test) (Generic emission standard for industrial environments) (CISPR22 - EMC) (CISPR11 - EMC)							

USER INSTRUCTIONS

- 1) Description:** DIN rail Universal Active Oring Controller for redundant connection to a common Load of 2 DC Power supplies of same rating, with any voltage in the range 12...85Vdc and Load Current ≤ 50A.
Warning: voltages ≥ 60Vdc are dangerous! Use appropriate safety rules!
- 2) Installation:** use DIN-rails according to EN 60715. Installation should be made vertically (see Fig.4). For better device stability fix the rail to the wall close to the point where the device is to be mounted. In order to guarantee sufficient convection, we recommend observing a minimum distance to other modules (see Fig.3).
- 3) Connections:** the device is equipped with pluggable screw terminals. To avoid sparks, do not connect or disconnect the connectors before having previously turned-off input power and waited for internal capacitors discharge (minimum 1 minute)
 In order to comply with UL certification, use appropriate copper cables of indicated cross section, designed for an operating temperatures of:
 60°C for ambient up to 45°C
 75°C for ambient up to 60°C
 90°C for ambient up to 70°C
 Strip the connecting ends of the wires according to the indication and ensure that all strands of a stranded wire enter the terminal connection (see Fig.5)
- 4) Input/Output connection:** The device is suitable for SELV and PELV circuitry (if you use a source that having Uout higher 60Vdc is not a SELV device)
 Check Uout before connecting the power supply to the load.
- 5) Operating:** Connect the OR50 as indicated in Fig.7.
 Turn on power supply "A" and adjust the load voltage to the needed level by measuring directly at the load.
 Turn on power supply "B". Trim its voltage until the green LED in the OR50 bar-graph is lit. At this moment power supplies "A" and "B" share the load with balanced currents.
 In case one of the two power supplies does not operate anymore the load is supplied by the second one without any interruption.
- 6) Status Signal:** OR50 provides specific status signals related to:
- acknowledgment of the power supplies availability (correct output voltage for each) (OR OK)
 - correct current share between the two power supplies (SHARE OK)
 - load current > 50A (OVERLOAD)
- These signals are displayed on the OR50 front panel trough LEDs and are also present on 2 relays dry contacts for remote monitoring of the unit.
IN1 (IN2) OK LED: Indicates that the voltage present on IN1 (IN2) is > 0.9*Vout. It is an indication of the presence of the correct voltage from the power supply connected to IN1 (IN2).
FAIL LED: Indicates that the system has a problem and the redundancy is no more guaranteed. It can have 3 status
- OFF continuously: means that the redundancy is guaranteed. In this status the OR-OK dry contact is closed
 - ON continuously: means that the voltage on one of the two inputs is not present or out of range. In this status the OR-OK dry contact is open
- Blinking at 0.5Hz: means that the output current has exceeded the maximum of 50A. In this status the SHARE-OK dry contact is closed and open at 0.5Hz rate (1s ON / 1s OFF).
Current share bar-graph: Indicates the current distribution between the two power supplies. The current balancing is calculated in the following way: $unbal = \frac{(I1-I2)}{(I1+I2)}$; $bal = 0\%$ means perfect current sharing while $unbal = 100\%$ (-100%) indicates that the load current is provided only by power supply 1 (2).
 The central green LED has a threshold of around ±15% current unbalancing, while the two external red LEDs are actives when the current unbalancing is greater than 60%. When one of the two red LEDs is on the SHARE-OK dry contact is open.
Note: when the load current is <2A the bar-graph green LED is always on and the SHARE-OK dry contact is always closed.
 The current unbalancing is not calculated when the load current is <2A.
OR-OK relay dry contact: It acts in exactly the same way as the FAIL LED. It is closed when the redundancy is guaranteed and open in case of failure. The relay contact rating is 24V/1A
SHARE-OK relay dry contact: It is closed when the load current unbalance is <60% and open when the current unbalance is >60% indicating that the current sharing between the two sources is lost. It toggles at 0.5Hz rate (1s closed / 1s open) when the load current exceeds 50A.
- 7) Environmental:** these products are IP20 (according to IEC 60529, UL not evaluated), and therefore chemicals/solvents, cleaning agents and other liquids must not be used.
- 8) Environment:** these power supplies are SMPS for use in applications within a Pollution Degree 2, overvoltage category II environment (overvoltage category III according to EN50178 and UL508). Do not use in wet area or subject to moisture. These products are designed for indoor use only. Carefully recycle the product and related batteries according to local regulations.
- 9) Intended use:** these are isolated devices suitable for SELV and PELV circuitry and are designed to be mounted on DIN rail and installed inside a protective enclosure. They are intended for general use such as in industrial control, communication, and instrumentation equipment.
 If the power supply is used in a way not specified in this manual, the protection provided by the equipment may be impaired. Don't use these devices in applications where malfunction may cause injury or death.
- 10) Radio interference:** this is an electrical appliance according to EN55032, class A. They may cause radio interference in residential areas.

Fig.1 Connections	Fig.2 Dimensions	Fig.3 Distances															
 <p>(1) Input PS1 50A Max. (2) Input PS2 50A Max. (3) Output Load 50A Max. (4) Diagnostic Output: OR OK (dry contact, NC output OK) (5) Diagnostic Output: SHARE OK (dry contact, NC output OK) (6) Green LED: IN1 OK (7) Green LED: IN2 OK (8) Red LED: FAIL (9) Current share Bar-graph</p> <p>Input DC Line:</p> <ul style="list-style-type: none"> ▪ IN1 + = Positive DC ▪ IN1 - = Negative DC ▪ IN2 + = Positive DC ▪ IN2 - = Negative DC <p>Output DC Line:</p> <ul style="list-style-type: none"> ▪ OUT + = Positive DC ▪ OUT - = Negative DC 	 <table border="1" data-bbox="710 1780 1005 1892"> <thead> <tr> <th>Dimension</th> <th>mm (inc)</th> </tr> </thead> <tbody> <tr> <td>W</td> <td>40.0 (1.57)</td> </tr> <tr> <td>D</td> <td>110.0 (4.33)</td> </tr> <tr> <td>H</td> <td>115.0 (4.52)</td> </tr> </tbody> </table>	Dimension	mm (inc)	W	40.0 (1.57)	D	110.0 (4.33)	H	115.0 (4.52)	 <table border="1" data-bbox="1061 1780 1460 1892"> <thead> <tr> <th>Distance</th> <th>mm (inc)</th> </tr> </thead> <tbody> <tr> <td>A</td> <td>20 (0.8)</td> </tr> <tr> <td>B</td> <td>20 (0.8)</td> </tr> </tbody> </table>		Distance	mm (inc)	A	20 (0.8)	B	20 (0.8)
Dimension	mm (inc)																
W	40.0 (1.57)																
D	110.0 (4.33)																
H	115.0 (4.52)																
Distance	mm (inc)																
A	20 (0.8)																
B	20 (0.8)																

Fig.4
Mounting / Dismounting Instructions

For DIN rail fastening according to IEC 60715 TH35-7.5(-15)

Mounting as shown in figure, with input terminals on lower side, with suitable cooling and maintaining a proper distance between adjacent devices as specified in the I.S. manual of each family.

Mounting:

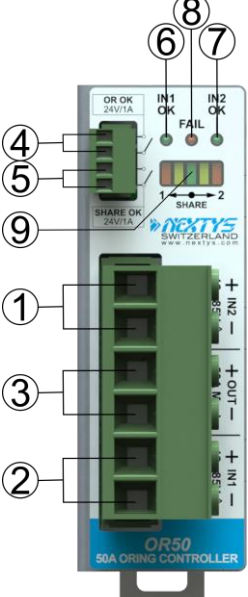
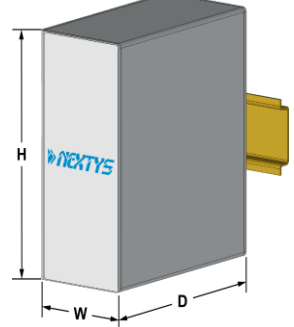
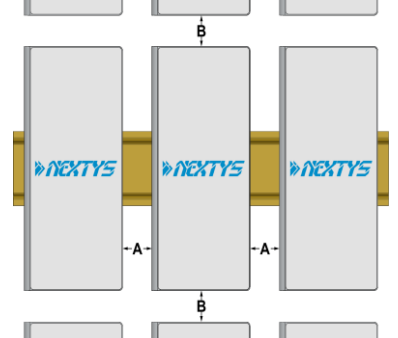
1. Tilt the unit slightly backwards.
2. Fit the unit over the top edge of the rail.
3. Slide it downward until it hits the stop.
4. Press against the bottom for locking.

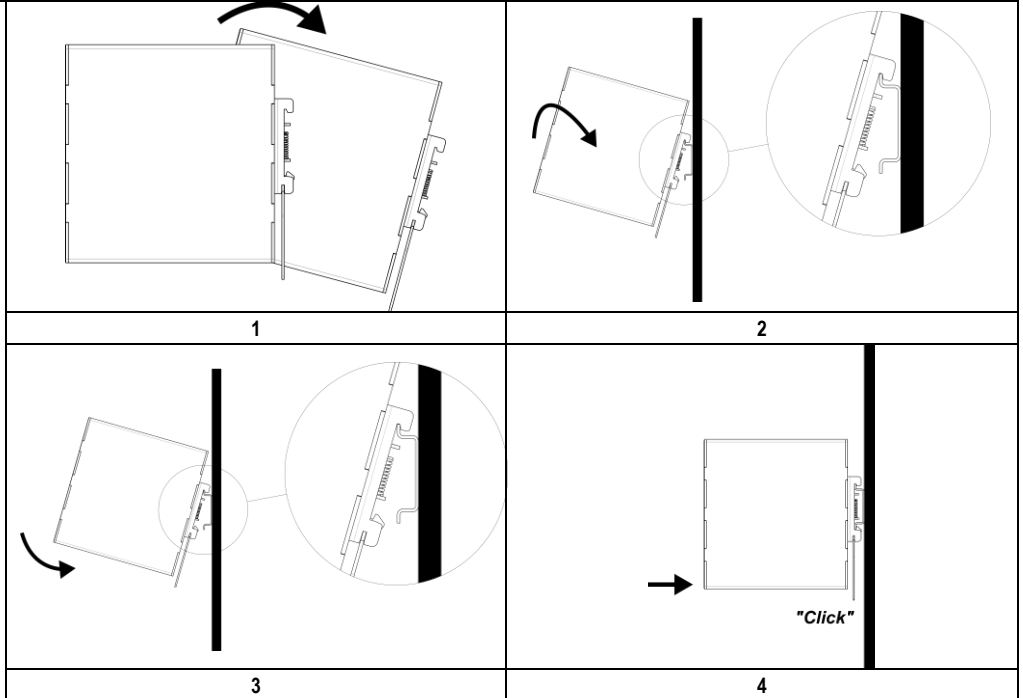

Dismounting:

1. Pull down the slide clamp lever
2. Tilt the unit upward
3. Unhook the unit from the rail

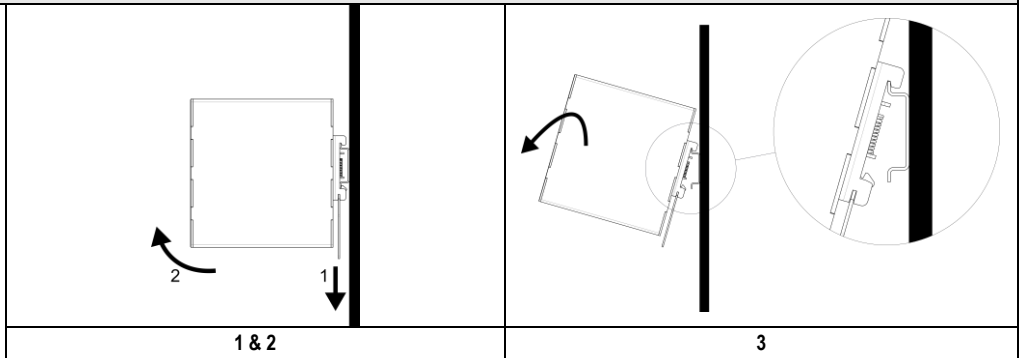

Fig.5
Recommended connecting cable

	<p>Recommended Tightening torque</p> <p>Input / output 1.2Nm 10.4 lbf in</p> <p>Signals 0.2-0.25Nm 1.17-2.21 lbf in</p>		<p>Input / output Solid: 0.75-16.0mm² / 18-6AWG Stranded: 0.75-16.0mm² / 18-6AWG L: 13-14mm / 0.51-0.55in</p> <p>Signals Solid: 0.05-1.5mm² / 30-14AWG Stranded: 0.05-1.5mm² / 30-14AWG L: 5-6mm / 0.20-0.24in</p>
--	--	--	--

Fig.6
Input protection
 The Device is provided in input against the Reverse polarity connection.

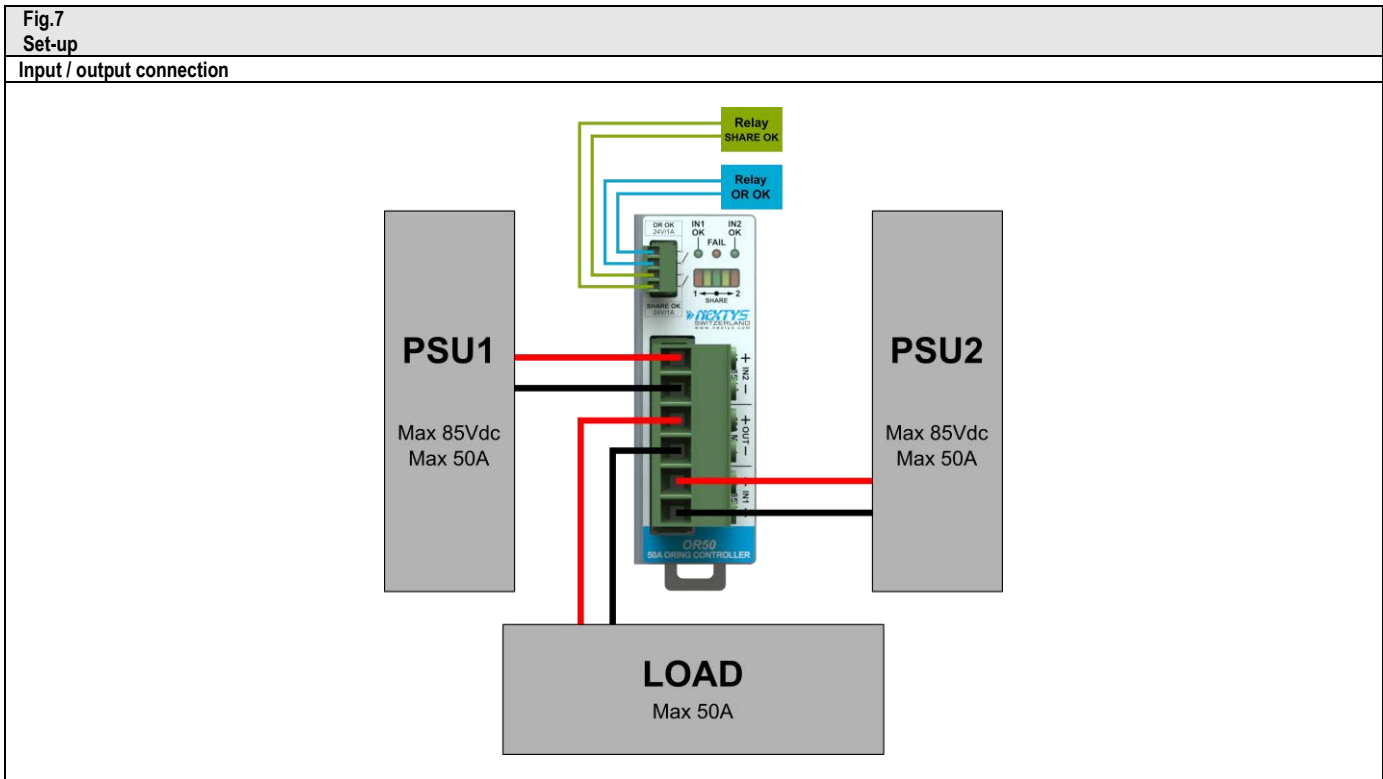

Fig.8
Environment

Operating temperature - 40°C...75°C 5...95% r.H. non condensing UL certified up to 75°C	Derating No Derating
---	------------------------------------

Note:

- Data may change without prior notice in order to improve the product.
- Please refer to the latest version of the "Instruction Manual" for each product by visiting www.nextys.com

See also the products below that can be used in conjunction with OR50 units:

- This device can be used in conjunction with every each our power supply that is able to provide an regulated Uout included between 12...85Vdc and 50A Max.