

DCW20

960W COMBO DC UPS / DC-DC Converter

User Manual



DISCLAIMER

TDK-Lambda Switzerland SA reserves the right to make changes without further notice to any products herein.

TDK-Lambda Switzerland SA makes no warranty, representation or guarantee regarding the suitability of its products for any particular purpose, nor does *TDK-Lambda Switzerland SA* assume any liability arising out of the application or use of any product, and specifically disclaims any and all liability, including without limitation consequential or incidental damages. "Typical" parameters which may be provided in *TDK-Lambda Switzerland SA* data sheets and/or specifications can and do vary in different applications and actual performance may vary overtime.

All operating parameters, including "Typicals", must be validated for each customer application by customer's technical experts. *TDK-Lambda Switzerland SA* does not convey any license under its patent rights nor the rights of others. *TDK-Lambda Switzerland SA* products are not designed, intended, or authorized for use as components in systems intended for surgical implant into the body, or other applications intended to support or sustain life, or for any other application in which the failure of the *TDK-Lambda Switzerland SA* product could create a situation where personal injury or death may occur. Should Buyer purchase or use *TDK-Lambda Switzerland SA* products for any such unintended or unauthorized application, Buyer shall indemnify and hold *TDK-Lambda Switzerland SA* and its officers, employees, subsidiaries, affiliates, and distributors harmless against all claims, costs, damages, and expenses, and reasonable attorney fees arising out of, directly or indirectly, any claim of personal injury or death associated with such unintended or unauthorized use, even if such claim alleges that *TDK-Lambda Switzerland SA* was negligent regarding the design or manufacture of the part.

The Customer should ensure that it has the most up to date version of the document by contacting its local *TDK-Lambda Switzerland SA* office. This document supersedes any earlier documentation relating to the products referred to herein. The information contained in this document is current at the date of publication. It may subsequently be updated, revised or withdrawn.

The Customer should ensure that *TDK-Lambda Switzerland SA* product uses the most up to date Software and Firmware provided on *TDK-Lambda Switzerland SA* website to ensure reliable operation of the system.

All Trade Marks recognized. Specifications and information herein are Subject to change without notice.

1	Product description	5
2	Features and benefits	6
3	Functional description	6
3.1	UPS mode	7
3.1.1	Backup	8
3.1.2	Battery health monitor	8
3.1.3	Battery charger	9
3.1.4	Coulomb counter	10
3.1.5	PC shutdown and automatic restart	11
3.1.6	Cold start	12
3.1.7	Blink output on backup	12
3.1.8	Battery Cycling	13
3.2	DC/DC mode	14
3.2.1	Parallel operation	15
3.3	Current limit	15
3.3.1	Current limit in UPS mode	15
3.3.2	Current limit in DC/DC mode	16
3.4	Inhibit	16
3.5	Shutdown and reset on request	16
3.6	Modbus	17
4	User interface	22
4.1	Status	23
4.2	Settings	23
4.2.1	Modbus address	24
4.2.2	Modbus baudrate	24
4.2.3	Modbus parity	24
4.2.4	Modbus stop bits	24
4.2.5	Battery type	24
4.2.6	Battery charge voltage	24
4.2.7	Battery charge current	25
4.2.8	Battery float voltage	25
4.2.9	Battery low voltage	25
4.2.10	Battery deep discharge voltage	25
4.2.11	Battery max. discharge current	25
4.2.12	Battery capacity - Supercap capacitance	25
4.2.13	Battery min. temperature	25
4.2.14	Battery max. temperature	26
4.2.15	Battery lifetime	26
4.2.16	Ri alarm mode	26
4.2.17	Ri nom.	26
4.2.18	Ri max. variation	26
4.2.19	Operating mode	26
4.2.20	Nominal output voltage	26
4.2.21	Max. input current	27
4.2.22	Max. output current	27
4.2.23	Max. Backup time enable	27
4.2.24	Max. backup time	27
4.2.25	Buzzer enable	27
4.2.26	Relay 1 configuration	28
4.2.27	Relay 2 configuration	28
4.2.28	Inhibit polarity	28
4.2.29	DC/DC output mode	28
4.2.30	Output enable	28
4.2.31	Aux enable	29
4.2.32	Cold start on inhibit toggle	29
4.2.33	Cold start on battery connection	29
4.2.34	PC shutdown enable	29
4.2.35	PC automatic restart enable	29
4.2.36	PC shutdown delay	29
4.2.37	PC shutdown time	29
4.2.38	PC restart minimum time	30

4.2.39	PC off detection current threshold	30
4.2.40	PC off detection timer	30
4.2.41	Blink output on backup enable.....	30
4.2.42	Blink output on backup Ton	30
4.2.43	Blink output on backup Toff	30
4.2.44	Output short circuit latch enable	30
4.2.45	Output short circuit detection voltage threshold	31
4.2.46	High inrush load enable	31
4.2.47	UPS not ready SoC threshold.....	31
4.2.48	UPS near empty SoC threshold.....	31
4.2.49	Lock settings	31
4.2.50	Delayed device shutdown time	31
4.2.51	Delayed device reset time	32
4.2.52	Backup start threshold	32
4.2.53	Battery cycle	32
4.2.54	Battery cycle every.....	32
4.2.55	Battery cycle day.....	32
4.2.56	Battery cycle hour	32
4.2.57	Battery cycle minute.....	32
4.2.58	Battery cycle SoC threshold	33
4.2.59	Battery cycle time threshold.....	33
4.2.60	Battery installation date.....	33
4.2.61	Battery charge cycles.....	33
4.3	Info.....	33
4.3.1	Firmware version.....	33
4.3.2	Firmware subversion	33
4.3.3	Build date	33
4.3.4	Build time.....	34
4.3.5	Serial number	34
4.3.6	Boot cycles	34
4.3.7	Operating time.....	34
4.3.8	Battery operating time	34
4.3.9	Next battery cycle.....	34
4.4	Logs	35
4.4.1	Info	35
4.4.2	Alarms	37
4.4.3	Events	40
4.5	Wizard.....	41
5	Technical Specifications	41
6	Installation procedure	41

1 Product description

⚠ Use latest device Documentation, Software and Firmware to ensure reliable operation of the system (downloadable from www.nextys.com).

DCW20 is a microprocessor controlled unit that can perform 2 functions:

1. UPS rated 960W/20A usable in any system rated 12...48Vdc
2. DC/DC converter (non isolated) rated 960W/20A usable in any combination of IN/OUT voltages 12...48Vdc

For the UPS function, it may use 1 battery of 12V, independently of the operating load voltage. For any supply voltages (12...48Vdc) it may use also multiple battery configuration (10...58Vdc). DCW20 monitors the voltage coming from a DC power supply and in case of power failure a backup battery is supplying the energy to the load. In normal condition the battery is kept charged by an integrated battery charger supporting various battery chemistries.

As a DC/DC converter (no battery present) the input must be connected to the battery connector. The input voltage is converted to any output voltage as per the set-up.

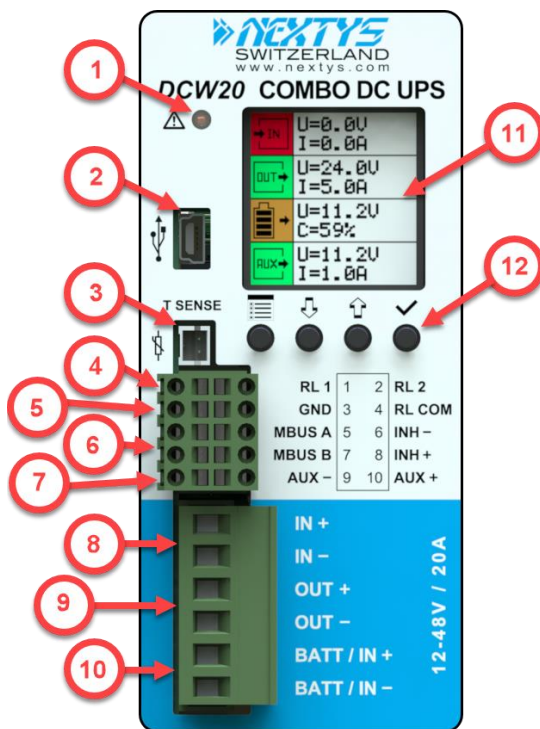

Figure 1: Front panel view

1. **Alarm LED indicator:** ON when the unit is in backup. Blinks at 1Hz rate in case of error.
2. **Modbus over USB:** Used to connect a PC running **POWERMASTER** or custom application for remote monitoring and controlling. Firmware update is also possible through USB connection.
3. **Temperature sensor:** Optional temperature sensor (P/N: WNTC-2MT) to measure the battery temperature for protection and temperature compensated charge method.
4. **Relays dry contacts:** 2 relays are present for remote monitoring. See §4.2.26 for more details.
5. **Modbus over RS485:** Used to connect a PC running **POWERMASTER** or custom application for remote monitoring and controlling. Firmware update is also possible through RS485 connection.
6. **Inhibit input:** A voltage between 5VDC and 30VDC applied to this input activates the inhibit function (§3.4).
7. **Auxiliary output supply:** Maximum 5A supply from the battery (unregulated).
8. **Input connection:** 2 poles are provided for input connection. This must be connected to a power supply rated 12...48VDC.
9. **Output connection:** 2 poles are provided for output connection. It must be connected to the load to be backed up.
10. **Battery / DC/DC input connection:** 2 poles are provided for battery connection. This must be connected to the battery in UPS mode or to the power supply in DC/DC mode. Although the unit is protected the correct polarity must be respected.
11. **Display area:** provides information regarding the device status.
12. **Control keys:** 4 push buttons are provided to navigate through the menus and to select the various functions.

2 Features and benefits

The main features are:

- Integrated battery charger for 12...48V multi-chemistries batteries with a charging current up to 20A
- Can be operated with SUPERCAP capacitors instead of batteries
- 20 A or 960W rated load
- Automatic sensing of input voltage, load current and battery current
- Battery protection against reverse polarity connection and overcurrent
- Battery health monitoring system: measuring battery resistance, battery temperature, charge/discharge cycles and Coulomb counter
- User settable maximum backup time
- Remote inhibit input
- Connection for a battery thermal sensor (optional)
- Modbus over USB and RS-485 interfaces for control and monitoring
- Auxiliary output from the battery voltage (max. 5A), protected against overcurrent/short circuit
- Suitable for energy management applications
- Suitable for **POWERMASTER** software (available for Windows and Android)

Embedded user interface:

- 4 keys and 1 color graphic LCD display
- Allows online device configuration
- Displays the DCW20 status and alarms
- 2 Dry contacts for programmable status signals

Free PC and Android application **POWERMASTER** used for:

- Connection through Modbus
- Remote monitoring and configuration
- Firmware upgrade
- Same functionalities of the embedded user interface with the ease of the PC benefits

3 Functional description

DCW20 is a high performance digitally controller DC-UPS that can be used in any DC system with a rated voltage between 12V and 48V and up to 20A.

At the core of the device a bidirectional DC/DC buck-boost converter (see Figure 2) acts as a battery charger when the input supply is present. In case of a power outage (backup) the converter keeps the output voltage regulated draining power from the battery. The converter is digitally controlled.

The device is able to monitor the internal hardware in order to detect failures and/or malfunctions and alerts the user through both, the log system (§4.4) and own display.

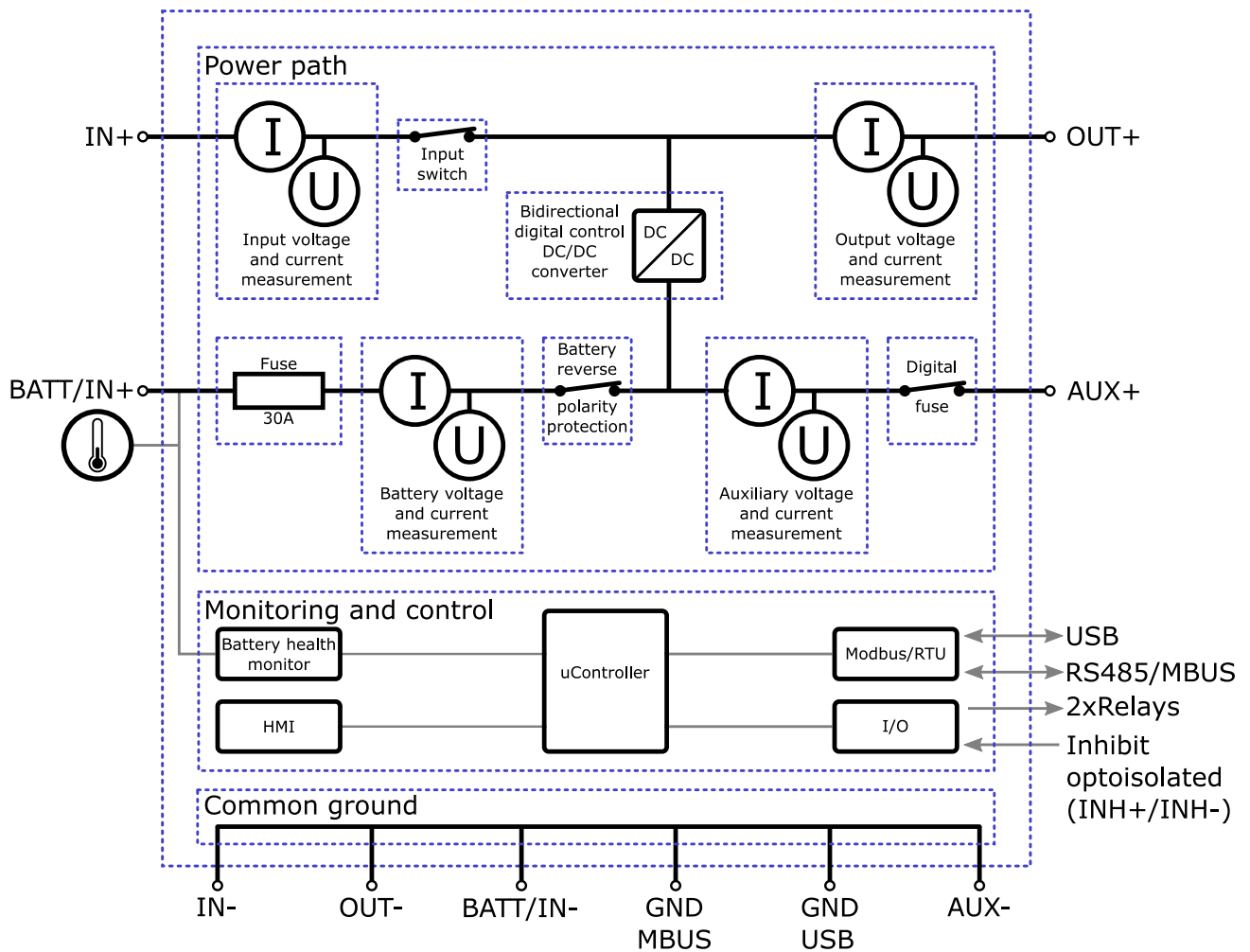

Figure 2: DCW20 simplified block diagram

3.1 UPS mode

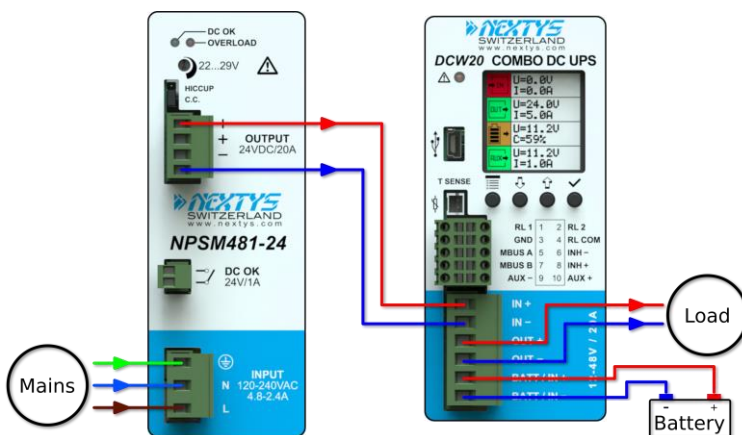

Figure 3: UPS connection example

In UPS mode the DCW20 protects a load from unwanted power interruption in case of mains failure. An example of UPS connection is given on Figure 3. When the input is present DCW20 acts as a bypass, connecting the input to the output via the input switch. Meanwhile, if required, the battery is charged. During bypass there is no voltage conversion, therefore the output supply voltage is equal to the input voltage. In case of power outage, the DCW20 takes energy from the battery to keep the output regulated at “Nominal output voltage” (§4.2.20).

3.1.1 Backup

The system is in backup mode if the supply for the output is sourced from the battery (input supply missing). During backup the battery is monitored continuously to prevent over discharge.

A **programmable backup timer** (§4.2.24) is also implemented in order to fix a maximum backup time during power outages. This allows preserving the battery life and shortening the recharge time, avoiding discharging the battery when not needed.

During backup the internal Coulomb counter is used to give an estimation of the residual charge of the battery.

Backup starts when the input voltage, expressed as percentage of the “*Nominal output voltage*” (§4.2.20), is lower than the value specified by the “Backup start threshold” (§4.2.520).

3.1.2 Battery health monitor

The battery health monitor is composed of:

- **Internal resistance measurement:** The resistance is periodically measured. The internal resistance is a good indicator of the battery health status; a sudden increase of the internal resistance indicates a potential problem on the battery or on the battery wiring.
- **Temperature measurement:** The battery temperature is monitored through an optional temperature sensor (*P/N: WNTC-2MT*). The battery charger takes into account the battery temperature and provides a temperature compensated charging voltage. In case of over or under temperature the system disconnects the battery to prevent damage.
- **Coulomb counter:** Estimates the remaining battery capacity and consequently the available backup time.
- **Deep discharge protection:** It protects against the deep discharge of the battery which can lead to its irreversible damage.

The battery internal resistance (R_i) is measured by draining a defined AC current through an active load (AL) from the battery and measuring the AC voltage drop across the load terminals. The principle is represented in Figure 4.

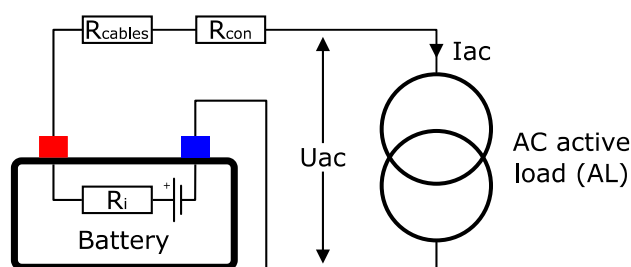

Figure 4: Internal resistance measurement

The measured resistance is the sum of the *battery internal resistance*, the *cables resistance* and the *connectors resistance*, therefore cabling problem such as loose connectors are also detected with R_i measurement.

When high capacity batteries and/or small and long cables are used $R_{cables} + R_{con}$ may be $> R_i$.

3.1.3 Battery charger

The battery charger supports **various chemistries** such as Lead-Acid, Nickel, Lithium and Supercapacitors. The charging algorithm for each chemistry is given below. Other charging algorithms can be implemented by request (contact factory).

The battery charger automatically reduces the current to avoid exceeding the maximum input current (§4.2.21) in case of high current load.

The user must set the following parameters to allow the charger to perform correctly:

- Battery type (§4.2.5).
- Battery charge voltage (§4.2.6)
- Battery charge current (§4.2.7)
- Battery float voltage (§4.2.8)

The battery charge terminates in case at least one of the following conditions are satisfied:

- **Low current:** The measured battery charge current is lower than 10% of the “*Battery charge current*” while the measured voltage is at least 98% of the “*Battery charge voltage*”.
- **Timer:** the charge is terminated after the battery has been charged for a predetermined amount of time. The value is automatically calculated by the device.

For Nickel batteries only, the following conditions are also checked:

- **Temperature Cutoff (TCO):** The battery temperature is higher than the “*Battery maximal temperature*” (§4.2.14) minus 3°C for more than one minute. For example, if the maximal battery temperature is set to 60°C, the charge terminates in case the temperature is higher than 57°C.
- **Rate of Temperature Increase ($\Delta T/dt$):** The battery temperature is rising at a rate equal or superior to 1°C/min. To avoid unattended end of charge do not place the system on an ambient with rapid changes of temperature (for example exposed to direct sunlight).

The charger voltage is independent on the input voltage (power supply), and is user settable.

Lead acid and lithium batteries share the same 3 stages charging algorithm as shown on Figure 5.

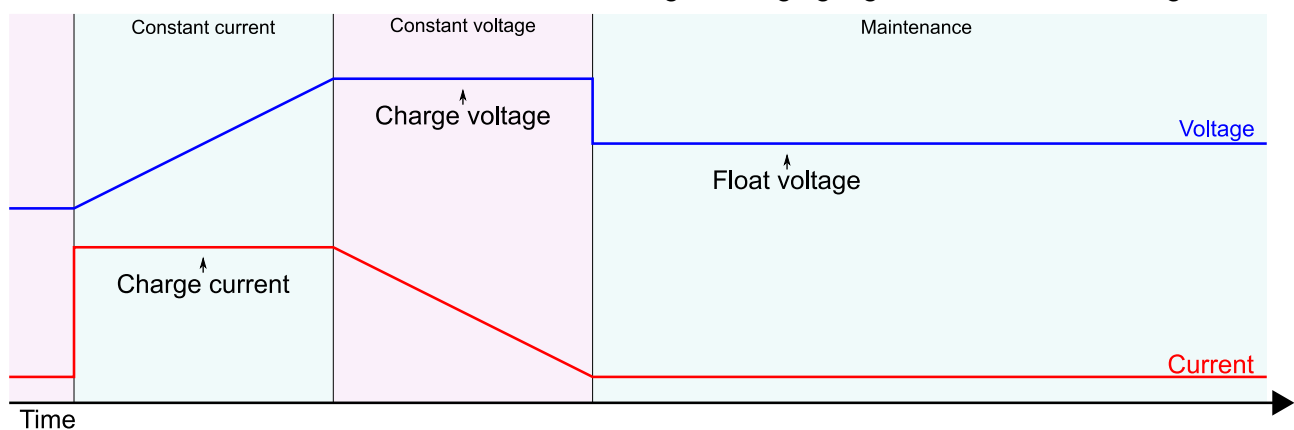

Figure 5: Lead acid and Lithium charging algorithm

For nickel batteries, during maintenance, the DCW20 gives pulses of 3s every 30s with a maximum current of 1/10 of “*Battery charge current*” and maximum voltage equal to “*Battery charge voltage*”.

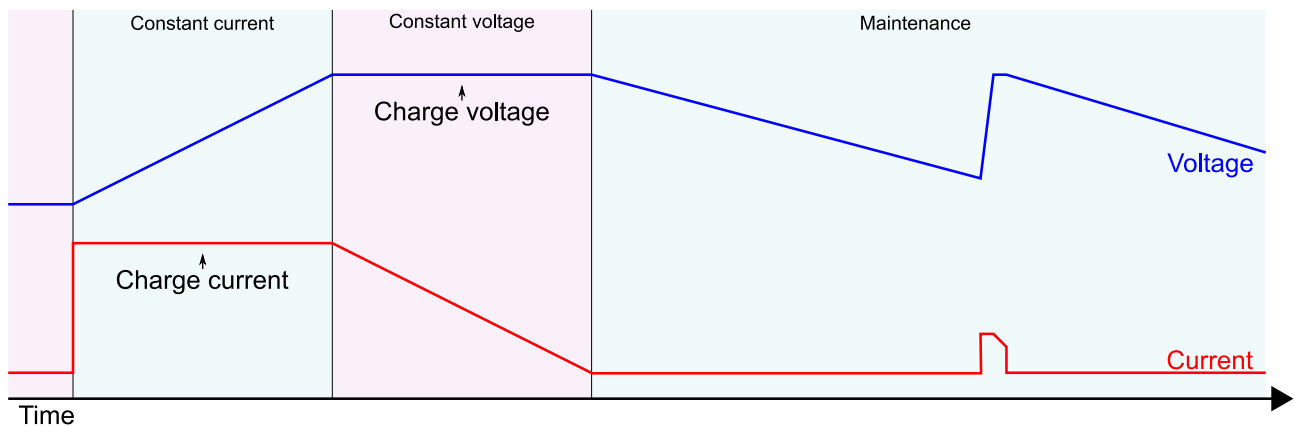

Figure 6: Nickel charging algorithm

For Supercapacitor after the constant current phase the algorithm goes directly to maintenance keeping the voltage at “Battery charge voltage”.

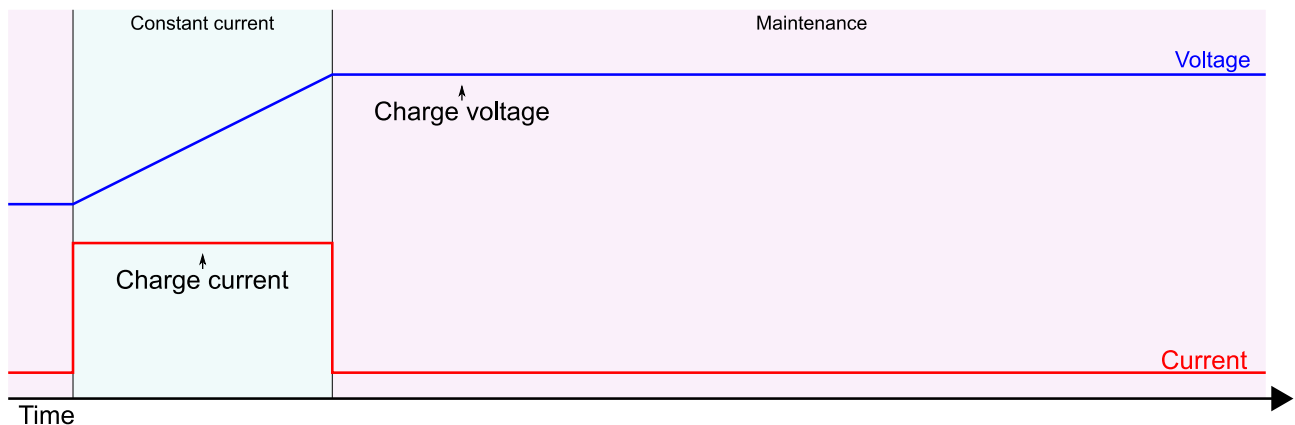

Figure 7: Supercapacitors charging algorithm

⚠ Warning: In order to avoid potentially hazardous situations including fire hazard, safety recommendations must be followed. Only authorized staff can install the unit.

⚠ Warning: For Lithium cells the balancing and protection circuit must be included in the battery pack.

⚠ Warning: For Nickel batteries the use of the external temperature sensor is mandatory. The sensor must be placed in contact with the battery.

3.1.4 Coulomb counter

DCW20 measures the current flowing from / to the battery to keep track of the capacity available on the battery. The capacity is measured in Ampere Hour [Ah]. The value shown is based on the following assumptions:

- The value shown is just informative and does not represent the real state of charge of the battery in some circumstances, for example if the battery is damaged.
- When the battery is connected for the first time or the system starts from OFF, the system assumes the battery is fully discharged and start with 0Ah counter.
- Once the battery is fully charged the system sets the counter to the nominal capacity specified by the user (§4.2.12).

3.1.5 PC shutdown and automatic restart

PC shutdown: In case the DCW20 is used to supply a PC it is possible to automatically shut down the PC after an adjustable time of backup. For this the PC must run the **POWERMASTER** application (provided free) and must be connected through Modbus. Optionally **POWERMASTER** can call a task on the PC before shutting down, for example to backup some sensitive data.

Automatic restart: DCW20 is able to automatically restart a PC which was powered OFF by mistake, for example in case of the Operating System (OS) crash. The user may adjust an output current threshold and a timer used for detecting the PC OFF status. In order to restart the PC the DCW20 toggles the output OFF and then ON again. User must enable in the PC BIOS the automatic start in case of supply ON.

The diagram below shows the DCW20 behavior when Shutdown and automatic restart is enabled.

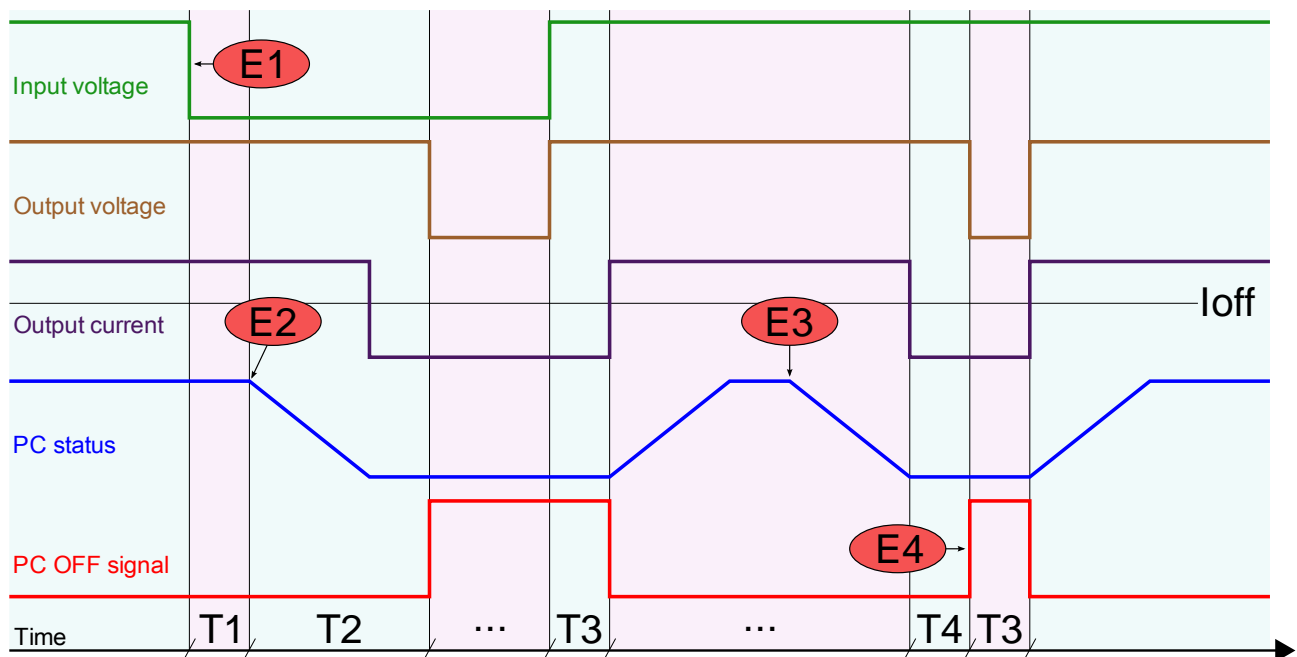

Figure 8: Shutdown and restart chart

Parameter	Name	Description
E1	<i>Backup</i>	Power failure on the line happens. System enters backup mode.
E2	<i>Automatic PC shutdown</i>	The POWERMASTER sends a shutdown command to the PC. Optionally: a task is called before shutdown.
E3	<i>Unexpected PC shutdown</i>	The PC shutdowns in an unexpected way, for example caused by OS crash.
E4	<i>PC restart</i>	DCW20 detects the PC being OFF because the output current was lower than Ioff current threshold for T4 time. As a consequence, DCW20 generates an ON->OFF->ON cycle on its output.
T1	<i>PC shutdown delay</i>	User settable (§4.2.36). Time between start of backup and start of PC shutdown procedure.
T2	<i>PC shutdown time</i>	User settable (§4.2.37). Time between start of shutdown procedure and output voltage OFF. This time must be set longer than the maximum time the PC takes to complete the shutdown.
T3	<i>PC restart minimum OFF time</i>	User settable (§4.2.38). T3 is the delay used between the return of the input voltage and the activation of the output. The

		same time is used by the automatic restart function as power OFF time to restart the PC. The value must be big enough for the PC to detect the supply ON->OFF->ON cycle to restart.
T4	<i>PC OFF detection timer</i>	User settable (§4.2.40). Minimum time at which the output current must be below the Ioff current threshold to trigger the automatic PC restart (PC supply ON->OFF->ON cycle).
Ioff	<i>PC OFF detection current threshold</i>	User settable (§4.2.39). Current threshold used to detect PC OFF status. This value must be lower than the minimum PC current consumption when this is ON.

Table 1: Shutdown and restart

The parameters are settable through the DCW20 user interface or using the **POWERMASTER** application. The checkbox “Run on startup” must be checked on **POWERMASTER** when PC shutdown function is used. To inhibit the software from calling the shutdown command user can select the “Inhibit shutdown” check box.

3.1.6 Cold start

The cold start is a procedure that allows turning ON the UPS without the input power. This procedure is used to turn ON the UPS to operate during a power interruption. This practice is also a method to see if the battery connected to the DCW20 is functional.



In cold start the DCW20 will remain ON for at least 60 seconds independently from the battery voltage (even when being under the deep discharge threshold), the inhibit input and the backup timer.

After the first 60 seconds the device stays ON until the battery is not deep discharged, the backup timer is not expired or the inhibit input is not active.

When cold started, the "Cold start" text is written beside the input icon on the status screen.

If the input supply returns during cold start the device reverts to normal operation.

To cold start the device the user as the following options:

- **From front panel:** Press and hold simultaneously the  and  buttons until you see the welcome message on the screen.
- **Remotely through inhibit input:** When enabled on the user settings (§4.2.32), the device cold starts toggling the inhibit status from true to false.
- **On battery connection:** When enabled on the user settings (§4.2.33), the device automatically cold starts when the battery, previously disconnected, is connected to the device.

Please, take in account that the battery connection can take up to 5 seconds to be detected and the inhibit state can take up to 3 seconds to be changed when in low power mode.

3.1.7 Blink output on backup

When this option is enabled, during backup, the output voltage switches on/off periodically with the timing defined on “Blink output on backup Ton” and “Blink output on backup Toff”. This function may be used on illumination application where is necessary to inform the person in the building that the lighting is running on batteries.

3.1.8 Battery Cycling

When this option is enabled the device schedules and activates a periodic battery discharge on a user settable day and time of the week. The user can select after how many weeks the system repeats the cycle. The purpose of this function is to verify the battery capacity/health.

The parameters related to this function are:

- **Battery cycle** (§4.2.53)
 - Enables or disables the function
- **Battery cycle every** (§4.2.54)
 - Indicates the time in weeks between two scheduled cycles
- **Battery cycle day** (§4.2.55)
 - Indicates the day of week on which perform the battery cycling
- **Battery cycle hour** (§4.2.56)
 - Indicate the hour at which start the battery cycling
- **Battery cycle minute** (§4.2.57)
 - Indicate the minute at which start the battery cycle
- **Battery cycle SoC threshold** (§4.2.58)
 - Indicate the state of charge in % at which the battery cycling must stop
- **Battery cycle time threshold** (§4.2.59)
 - Indicates the time, specified in minutes, from the start of battery cycling after which the process must stop

Into the device's SETTINGS menu the parameters "Battery cycle hour" (§4.2.56) and the "Battery cycle minute" (§4.2.57) are grouped into the "Battery cycle time" field.

Any time one of those parameters is modified or a start up is performed the battery cycle scheduling is recalculated.

The process is scheduled at time specified by "Battery cycle hour" (§4.2.56) and "Battery cycle minute" (§4.2.57) parameters at the first available day specified by "Battery cycle day" (§4.2.55) parameter.

Once the scheduled day and time are reached the battery cycle starts and the next event is scheduled at the same day, at the same time but after the number of weeks specified by "Battery cycle every" (§4.2.54) parameter.

When the battery cycle is in progress into the device's STATUS menu, at the top, the "Scheduled bat. disc." message is shown. The battery cycle in progress message is shown into the field "Next battery cycle" of the device's INFO menu, and into the tab Status of the **POWERMASTER** application.

The battery cycle is ended when one of the thresholds, specified by "Battery cycle SoC threshold" (§4.2.58) and by "Battery cycle time threshold" (§4.2.59), is reached. Once the programmed battery cycle process terminates the device turns back to nominal function.

If the scheduled battery cycle should start while the battery is charging, the battery cycle is skipped in order to permit to the battery a full recharge.

In case that the battery cycle is in progress and the input under voltage state is detected the battery cycle is immediately interrupted for preserve the battery charge in case of issues on the line.

If there is a need to interrupt an ongoing battery cycle process there are three methods.

The first method is disabling the battery cycle function through the device's menu SETTINGS by setting the "Battery cycle" field as "Disabled".

The second method is disabling the battery cycle function through the Modbus field “Battery cycle” (§4.2.53) setting field as “Disabled”.

The third method is stopping the current battery cycle through the Modbus field “Battery cycle stop”.

User can manually start the cycle using the Modbus field Battery cycle start, this will not affect the automatic scheduling. When starting manually, the cycle starts regardless of the battery status (e.g. battery charging).

The information about the next battery cycle is shown in the device’s INFO menu under “Next battery cycle” or through Modbus field “Next battery cycle” (§4.3.9).

Below a list of the logs related to this function:

Battery cycle active (§4.4.1.4)		
Primary value		Secondary value
0	Battery cycle ended	Minimum battery voltage during the battery cycle
1	Battery cycle started	Battery voltage at start of battery cycle

Battery cycle triggered by (§4.4.3.3)		
Primary value		Secondary value
1	Schedule	Not used
2	User	Not used

Battery cycle ended by (§4.4.3.4)		
Primary value		Secondary value
1	State of charge (SoC)	Not used
2	Time limit	Not used
3	Input UV (under voltage)	Not used
4	Battery in charge	Not used
5	User	Not used

3.2 DC/DC mode

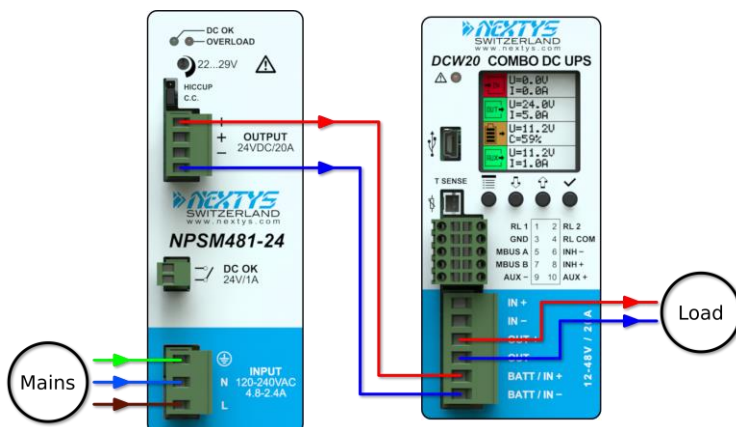

Figure 9: DC/DC connection example

DCW20 can be used as a high performance DC/DC converter. An example of DC/DC connection is given on Figure 9.

Any voltage between 10V to 55V can be converted to any voltage between 10V to 55V (step-up and step-down operation) with up to 20A input or output current.

Input and output are protected against over current with user settable limits (§3.3).

When used as a DC/DC converter the input supply must be connected to the battery connector as shown on Figure 9.

3.2.1 Parallel operation

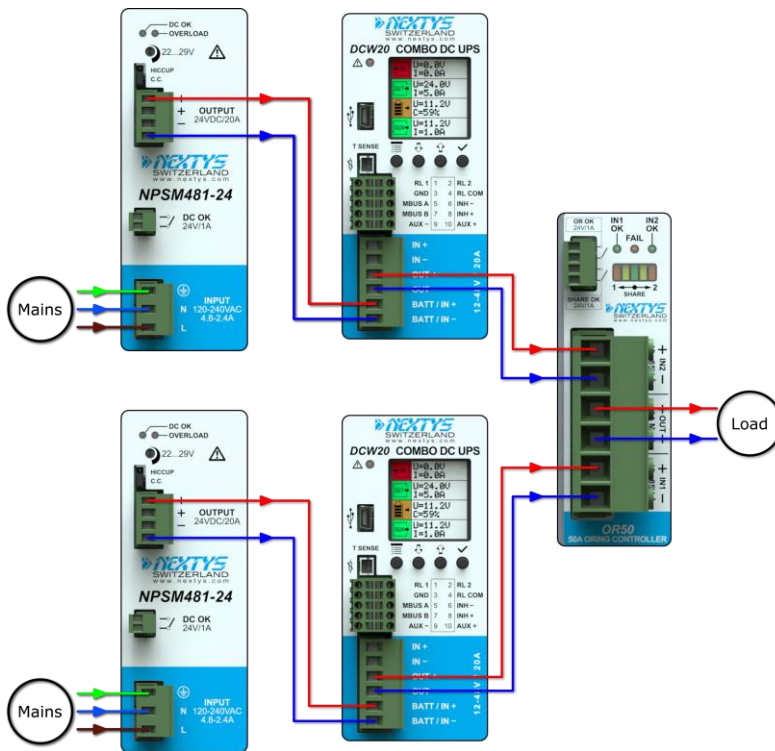

Figure 10: DC/DC parallel connection example with External redundancy module

When configured as DC/DC converter multiple DCW20 can be connected with output in parallel for power increase or redundancy.

In this mode of operation, the field “DC/DC output mode” (§4.2.29) must be set to “Parallel”.

In case of parallel for redundancy an external ORing module (for example OR50) is required.

For proper operation between the 2 units the cable length connecting the 2

DCW20 to the load must have the same length and cross-section.

For optimal current sharing it may be necessary to slightly adjust one of the 2 devices output voltage until the same current is delivered by the 2 units.

It is recommended to limit the load power to 80% of the sum of the individual output power of the paralleled units.

⚠ Parallel connection for power increase of multiple DCW20 units is not recommended in UPS mode. Contact factory for details.

3.3 Current limit

DCW20 has the ability to limit the current flowing through its input, output and battery terminals to a user settable threshold.

3.3.1 Current limit in UPS mode

In UPS mode DCW20 provides 4 different settings for the current limit:

- **Maximum input current** (§4.2.21), default 20A: it is used to limit the input current at a specified threshold. For example, if the DC power supply is rated less than 20A the threshold can be lowered to avoid too high current drain from the power supply. When the input current limit is reached, the battery charging current is limited; if the input current cannot be kept below the threshold due to excessive loading an input overcurrent alarm is triggered. When the input current is approaching the threshold, the measured input current is displayed with red fonts on the LCD.
- **Maximum output current** (§4.2.22), default 20A: it is used to limit the maximum current delivered to the load. When the threshold is reached due to excessive loading an output overcurrent alarm is triggered. When the output current is approaching the threshold, the measured output current is displayed with red fonts on the LCD.

- **Battery maximum charge current** (§4.2.7), default 0.5A (maximum settable 20A): it is used to limit the maximum charge current supplied to the battery. This threshold will be automatically reduced in such manner that the maximum input current limit (§4.2.21) is distributed to the load with priority towards the charging.
For example, if the maximum input current limit is 20A and the load needs 10A while the maximum charge current is set at 12A, the controller will limit the charging current automatically to 10A until the load will need <10A.
- **Battery maximum discharge current** (§4.2.11), default 20A: it is used to limit the maximum discharge current delivered from the battery during the backup function. When the threshold is reached due to excessive loading a battery overcurrent alarm is triggered and the output voltage starts to decrease. When the battery discharge current is approaching the threshold, the measured battery current is displayed with red fonts on the LCD.

3.3.2 Current limit in DC/DC mode

In DC/DC mode DCW20 provides 2 different settings for the current limit:

- **Maximum input current** (§4.2.21), default 20A: it is used to limit the input current at a specified threshold. For example, if the DC power supply is rated less than 20A the threshold can be lowered to avoid too high current drain from the power supply. When the input current limit is reached due to excessive loading an input overcurrent alarm is triggered. When the input current is approaching the threshold, the measured input current is displayed with red fonts on the LCD.
- **Maximum output current** (§4.2.22), default 20A: it is used to limit the maximum current delivered to the load. When the threshold is reached due to excessive loading an output overcurrent alarm is triggered and the output voltage starts to decrease. When the output current is approaching the threshold, the measured output current is displayed with red fonts on the LCD.

3.4 Inhibit

An **opto-isolated input** allows the inhibition of the backup function in UPS mode or switching off the output on DC/DC mode. The polarity of the input can be defined using the “*Inhibit polarity*” field (§4.2.28).

3.5 Shutdown and reset on request

The device offers the on request reset or shutdown feature.

There are two mode of reset/shutdown requests, the immediate and the delayed.

The first mode starts the shutdown/reset sequence immediately after a “Shutdown” or “Reset device” Modbus command (see §3.6 “*Commands*” section) is received by the DCW20.

The second mode starts the shutdown/reset sequence with a delay specified through Modbus fields “Delayed device shutdown time” (§4.2.50) and “Delayed device reset time” (§4.2.51).

Generally, the shutdown command is used to interrupt the ongoing backup process and to send the device into low power mode.

The reset command performs the reboot of the device, with the same effect as a device power cycle.

3.6 Modbus

DCW20 communicates through Modbus/RTU as specified on “[MODBUS over Serial Line](#)” and “[MODBUS APPLICATION PROTOCOL SPECIFICATION](#)” documents available on <http://www.modbus.org/>.

Table 2 contains the field types and Table 3 the mapped fields. For types bigger than 16bit, access all registers in one transaction (multiple register read or write) to ensure atomic operation.

Type	Modbus function codes		Description																						
	Read	Write																							
BIT	1,2	5,15	Single bit with value 0 or 1																						
SINT16	3,4	6,16	Signed 16 bit value (2's complement)																						
UINT16	3,4	6,16	Unsigned 16 bit value																						
SINT32	3	16	Signed 32 bit value (2's complement) Composed of 2 consecutive registers in big-endian order.																						
UINT32	3	16	Unsigned 32 bit value. Composed of 2 consecutive registers in big-endian order.																						
DATE	3	16	Time and date field. Composed of 4 Modbus registers as follows: <table border="1" style="margin-left: 40px;"> <thead> <tr> <th>Address offset</th> <th>Byte</th> <th>Description</th> </tr> </thead> <tbody> <tr> <td rowspan="2">0</td> <td>MSB</td> <td>Reserved, set to 0</td> </tr> <tr> <td>LSB</td> <td>Year-2000</td> </tr> <tr> <td rowspan="2">1</td> <td>MSB</td> <td>Month (1=January)</td> </tr> <tr> <td>LSB</td> <td>Day of the month</td> </tr> <tr> <td rowspan="2">2</td> <td>MSB</td> <td>Hour of the day (24h format)</td> </tr> <tr> <td>LSB</td> <td>Minutes</td> </tr> <tr> <td rowspan="2">3</td> <td>MSB</td> <td rowspan="2">Milliseconds</td> </tr> <tr> <td>LSB</td> </tr> </tbody> </table>	Address offset	Byte	Description	0	MSB	Reserved, set to 0	LSB	Year-2000	1	MSB	Month (1=January)	LSB	Day of the month	2	MSB	Hour of the day (24h format)	LSB	Minutes	3	MSB	Milliseconds	LSB
Address offset	Byte	Description																							
0	MSB	Reserved, set to 0																							
	LSB	Year-2000																							
1	MSB	Month (1=January)																							
	LSB	Day of the month																							
2	MSB	Hour of the day (24h format)																							
	LSB	Minutes																							
3	MSB	Milliseconds																							
	LSB																								

Table 2: Modbus types

Address	Type	R/W	Unit	Min.	Max.	Description
<i>Common</i>						
0x0010	DATE	R/W			R/W	Real time clock.
<i>Settings (see §4.2)</i>						
0x1000	UINT16	R/W	1	1	247	Modbus address.
0x1001	UINT16	R/W	1	1	5	Modbus baudrate. 1: 9600 baud 2: 19200 baud 3: 38400 baud 4: 57600 baud 5: 115200 baud
0x1002	UINT16	R/W	1	1	3	Modbus parity. 1: None 2: Even 3: Odd
0x1003	UINT16	R/W	1	1	2	Modbus stop bits.

Address	Type	R/W	Unit	Min.	Max.	Description
0x1010	UINT16	R/W	1	1	4	Battery type. 1: Lead 2: Nickel 3: Lithium 4: Supercapacitor
0x1011	UINT16	R/W	0.1V	10	58	Battery charge voltage.
0x1012	UINT16	R/W	0.1A	0.5	20	Battery charge current.
0x1013	UINT16	R/W	0.1V	10	58	Battery float voltage.
0x1014	UINT16	R/W	0.1V	5	58	Battery low voltage.
0x1015	UINT16	R/W	0.1V	5	58	Battery deep discharge voltage.
0x1016	UINT16	R/W	0.1A	5	21	Battery max. discharge current.
0x1017	UINT16	R/W	0.1Ah	1	1000	Battery capacity - Supercap capacitance.
0x1018	SINT16	R/W	1°C	-40	60	Battery min. temperature.
0x1019	SINT16	R/W	1°C	-40	60	Battery max. temperature.
0x101A	UINT16	R/W	1kh	1	100	Battery lifetime.
0x101B	UINT16	R/W	1	0	3	Ri alarm mode. 0: Disabled 1: Fix 2: Automatic 3: Automatic done
0x101C	UINT16	R/W	0.1mΩ	0	300	Ri nom.
0x101D	UINT16	R/W	1%	50	300	Ri max. variation.
0x1020	UINT16	R/W	1	1	2	Operating mode. 1: UPS 2: DC/DC
0x1021	UINT16	R/W	0.1V	10	58	Nominal output voltage.
0x1022	UINT16	R/W	0.1A	5	21	Max. input current.
0x1023	UINT16	R/W	0.1A	1	21	Max. output current.
0x1024	UINT16	R/W	1	0	1	Max. Backup time enable. 0: Disabled 1: Enabled
0x1025	UINT16	R/W	1min	1	1440	Max. backup time.
0x1026	UINT16	R/W	1	0	1	Buzzer enable. 0: Disabled 1: Enabled
0x1027	UINT16	R/W	1	0	65535	Relay 1 configuration (see §4.2.26).
0x1028	UINT16	R/W	1	0	65535	Relay 2 configuration (see §4.2.27).
0x1029	UINT16	R/W	1	1	2	Inhibit polarity. 1: Low 2: High
0x102A	UINT16	R/W	1	1	2	DC/DC output mode. 1: Single 2: Parallel
0x102B	UINT16	R/W	1	0	1	Output enable. 0: Disabled 1: Enabled
0x102C	UINT16	R/W	1	0	1	Aux enable. 0: Disabled 1: Enabled
0x102D	UINT16	R/W	1	0	1	Cold start on inhibit toggle. 0: Disabled 1: Enabled

Address	Type	R/W	Unit	Min.	Max.	Description
0x102E	UINT16	R/W	1	0	1	Cold start on battery connection. 0: Disabled 1: Enabled
0x1030	UINT16	R/W	1	0	1	PC shutdown enable. 0: Disabled 1: Enabled
0x1031	UINT16	R/W	1	0	1	PC automatic restart enable. 0: Disabled 1: Enabled
0x1032	UINT16	R/W	1s	1	3600	PC shutdown delay.
0x1033	UINT16	R/W	1s	1	600	PC shutdown time.
0x1034	UINT16	R/W	1s	1	60	PC restart minimum time.
0x1035	UINT16	R/W	0.1A	0	20	PC off detection current threshold.
0x1036	UINT16	R/W	1s	1	60	PC off detection timer.
0x1040	UINT16	R/W	1	0	1	Blink output on backup enable. 0: Disabled 1: Enabled
0x1041	UINT16	R/W	1s	10	600	Blink output on backup Ton.
0x1042	UINT16	R/W	0.1s	0.1	60	Blink output on backup Toff.
0x1043	UINT16	R/W	1	0	1	Output short circuit latch enable. 0: Disabled 1: Enabled
0x1044	UINT16	R/W	0.1V	3	58	Output short circuit detection voltage threshold.
0x1045	UINT16	R/W	1	0	1	High inrush load enable. 0: Disabled 1: Enabled
0x1046	UINT16	R/W	1%	10	90	UPS not ready SoC threshold
0x1047	UINT16	R/W	1%	10	90	UPS near empty SoC threshold
0x1048	UINT16	R/W	1	0	1	Lock settings 0: Disabled 1: Enabled
0x1049	UINT16	R/W	1s	1	600	Delayed device shutdown time
0x104A	UINT16	R/W	1s	1	600	Delayed device reset time
0x104B	UINT16	R/W	1%	80	95	Backup start threshold
0x1050	UINT16	R/W	1	0	1	Battery cycle
0x1051	UINT16	R/W	1week	1	52	Battery cycle every
0x1052	UINT16	R/W		1	7	Battery cycle day
0x1053	UINT16	R/W	1h	0	23	Battery cycle hour
0x1054	UINT16	R/W	1min	0	59	Battery cycle minute
0x1055	UINT16	R/W	1%	10	90	Battery cycle SoC threshold
0x1056	UINT16	R/W	1min	1	1440	Battery cycle time threshold
0x1100	DATE	R/W				Battery installation date.
0x1104	UINT16	R/W	1	0	65535	Battery charge cycles.
0x1105	UINT16	R	1	0	1	Battery cycle in progress
0x1106	DATE	R				Next battery cycle
Metering						
0x2000	SINT16	R	0.1V	0	60	Input voltage.
0x2001	SINT16	R	0.1A	0	40	Input current
0x2002	SINT16	R	0.1V	0	60	Output voltage.
0x2003	SINT16	R	0.1A	0	40	Output current.
0x2004	SINT16	R	0.1V	0	60	Battery voltage.
0x2005	SINT16	R	0.1A	-25	25	Battery current.
0x2006	SINT16	R	0.1V	0	60	Auxiliary voltage.

Address	Type	R/W	Unit	Min.	Max.	Description
0x2007	SINT16	R	0.1A	0	20	Auxiliary current.
0x2008	SINT16	R	0.1°C	-40	85	External temperature.
0x2009	SINT16	R	0.1mΩ	0	3000	Battery internal resistance.
0x200A	SINT16	R	0.1%	0	100	Battery charge percent.
0x200B	SINT16	R	0.1Ah	0	10000	Battery charge capacity.
0x2010	UINT16	R	1cycle	0	65535	Boot cycles.
0x2020	UINT32	R	1h	0	500000	Operating time.
0x2022	UINT32	R	1h	0	500000	Battery operating time.
Commands						
0x3000	BIT	W	1	0	1	Perform Ri measurement.
0x3001	BIT	W	1	0	1	Shutdown.
0x3002	BIT	W	1	0	1	Reset device.
0x3003	BIT	W	1	0	1	Battery cycle start
0x3004	BIT	W	1	0	1	Battery cycle stop
0x3005	BIT	W	1	0	1	Delayed device shutdown
0x3006	BIT	W	1	0	1	Delayed device reset
State (see §4.4)						
0x4000	BIT	R	1	0	1	Battery charging.
0x4001	BIT	R	1	0	1	Battery floating.
0x4002	BIT	R	1	0	1	Battery discharging.
0x4010	BIT	R	1	0	1	Battery disconnected.
0x4011	BIT	R	1	0	1	Battery Ri too high.
0x4012	BIT	R	1	0	1	Battery under temperature.
0x4013	BIT	R	1	0	1	Battery over temperature.
0x4014	BIT	R	1	0	1	Battery lifetime elapsed.
0x4015	BIT	R	1	0	1	Battery charge failure.
0x4016	BIT	R	1	0	1	Battery SoC < 25%.
0x4017	BIT	R	1	0	1	Battery over discharge current.
0x4018	BIT	R	1	0	1	Battery low.
0x4019	BIT	R	1	0	1	Battery deep discharged.
0x4020	BIT	R	1	0	1	USB powered.
0x4021	BIT	R	1	0	1	Cold start.
0x4022	BIT	R	1	0	1	PC shutdown.
0x4023	BIT	R	1	0	1	PC power off.
0x4024	BIT	R	1	0	1	External temperature sensor presence.
0x4025	BIT	R	1	0	1	Inhibit.
0x4026	BIT	R	1	0	1	Output disabled.
0x4027	BIT	R	1	0	1	Auxiliary output disabled.
0x4028	BIT	R	1	0	1	UPS not ready
0x4029	BIT	R	1	0	1	UPS near empty
0x402A	BIT	R	1	0	1	Battery cycle active
0x4030	BIT	R	1	0	1	Backup.
0x4031	BIT	R	1	0	1	Input under voltage.
0x4032	BIT	R	1	0	1	Input over voltage.
0x4033	BIT	R	1	0	1	Output under voltage.
0x4034	BIT	R	1	0	1	Output over voltage.
0x4035	BIT	R	1	0	1	Output overload.
0x4036	BIT	R	1	0	1	Input over current.
0x4037	BIT	R	1	0	1	Auxiliary output overload.
0x4038	BIT	R	1	0	1	External temperature sensor error.
0x4039	BIT	R	1	0	1	Backup time left < 25%.
0x403A	BIT	R	1	0	1	Warning over temperature.
0x403B	BIT	R	1	0	1	Error over temperature.

Address	Type	R/W	Unit	Min.	Max.	Description
0x403C	BIT	R	1	0	1	Output short circuit
0x403D	BIT	R	1	0	1	Internal Failure

Table 3: Modbus fields

4 User interface

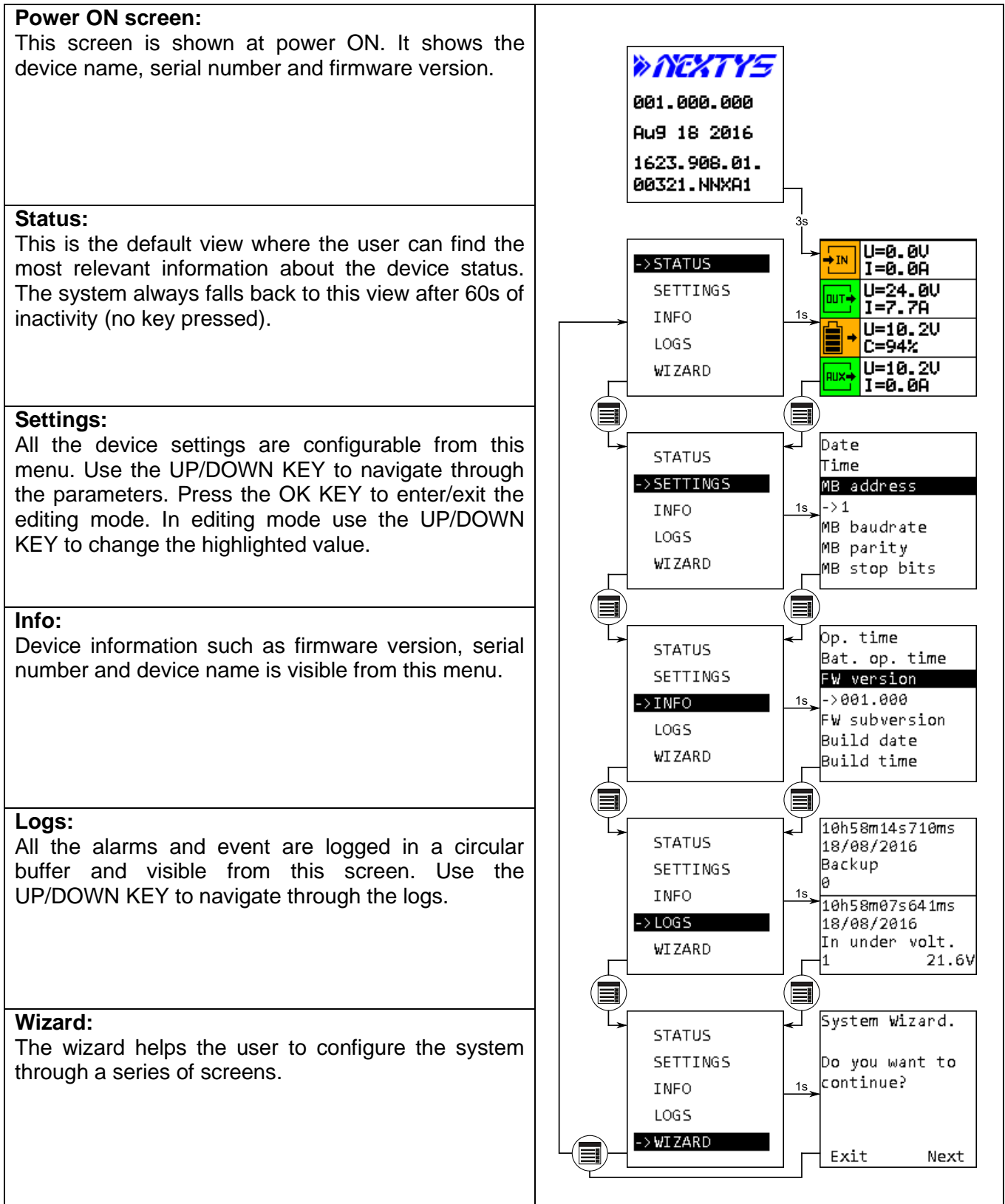

Table 4: User interface layout









Symbol	Name	Function
	MENU KEY	Scrolls between menus.
	DOWN KEY	Scrolls down menus and values.
	UP KEY	Scrolls up menus and values.
	OK KEY	Confirms selection.

Table 5: User interface key

4.1 Status

The status screen shows the measurement and statuses to ease the system diagnostic. The screen is divided in sections identified by the symbols shown below:

	Input: The measured input voltage and current is shown in this section.
	Output: The measured output voltage and current is shown in this section.
	Battery: The battery voltage, current, temperature, resistance and charge are shown in this section. During charging and discharging the symbol background color changes to orange and the number of bars drawn inside reflects the charge status. During discharging and charging an arrow drawn beside the symbol reflects the direction of the current flowing through the battery, pointing towards the battery during charging. Battery section is not present in DC/DC mode.
	Auxiliary: The measured auxiliary output voltage and current is shown in this section.

For each section the icon background color reflects its status, green on healthy state or red/orange otherwise.

Furthermore, in case of alarm a message appears on the screen after 60s of inactivity (no key pressed).





	U=0.0V I=0.0A
	U=24.0V I=7.7A
	U=10.2V C=94%
	U=10.2V I=0.0A

Figure 11: UPS status screen



DC/DC mode	
	U=10.3V I=19.1A
	U=24.0V I=7.7A
	U=10.2V I=0.0A

Figure 12: DC/DC status screen

1/1	
Battery disconnected. Check battery and connection.	
Bat U=0.0V	

Figure 13: Alarm screen

4.2 Settings

The setting menu contains all the configurable parameters available to the user. Use the UP/DOWN KEY to navigate through the menu items. Press the OK KEY to enter and exit the editing mode, exiting the edit mode stores and activates the new configuration. While in editing mode use the UP/DOWN KEY to change the selected value. All settings are also accessible via Modbus at the specified address. All the battery related settings are ignored in DC/DC operating mode.

The locking/unlocking of the settings editing can be done using the field “Lock settings” into the “SETTINGS” menu (§4.2.49) or through the Modbus “Lock settings” field.

The locking/unlocking of the settings editing can also be done keeping pressed simultaneously the \uparrow (Up) and \downarrow (Down) buttons for at least 3 seconds while into the SETTINGS menu. There are no notifications using this procedure.

When the lock is active, trying to edit a parameter using the device’s buttons shows a “Settings Locked” message for a couple of seconds. It is always possible to edit the setting through Modbus regardless the status of the lock.

4.2.1 Modbus address

Default value 1	Range 1...247	Resolution 1
Unit NA	LCD name Modbus address	Modbus address 0x1000

The Modbus slave address for the device. The same address is used for USB and RS485 connection.

4.2.2 Modbus baudrate

Default value 38400	Values (Modbus value) 9600 (1), 19200 (2), 38400 (3), 57600 (4), 115200 (5)	
Unit NA	LCD name Modbus baudrate	Modbus address 0x1001

The baudrate for Modbus over RS485 serial port.

4.2.3 Modbus parity

Default value Even	Values (Modbus value) None (1), Even (2), Odd (3)	
Unit NA	LCD name Modbus parity	Modbus address 0x1002

The parity for Modbus over RS485 serial port. Available values are None, Even, Odd.

4.2.4 Modbus stop bits

Default value 1	Range 1, 2	Resolution 1
Unit NA	LCD name Modbus stop bits	Modbus address 0x1003

The parity for Modbus over RS485 serial port.

4.2.5 Battery type

Default value Pb	Values (Modbus value) Lead (1), Nickel (2), Lithium (3), SuperCap (4)	
Unit NA	LCD name Bat. type	Modbus address 0x1010

Defines the type of battery connected to the device. See §3.1.3 for details about the different charging algorithms.

4.2.6 Battery charge voltage

Default value 10V	Range 10...58V	Resolution 0.1V
Unit Volts	LCD name Bat. charge U	Modbus address 0x1011

The maximum voltage applied to the battery while charging. See §3.1.3 for details about the use of this parameter on the different charging algorithms.

4.2.7 Battery charge current

<i>Default value</i> 0.5A	<i>Range</i> 0.5...20A	<i>Resolution</i> 0.1A
<i>Unit</i> Amperes	<i>LCD name</i> Bat. charge I	<i>Modbus address</i> 0x1012

The maximum current sourced to the battery while charging. See §3.1.3 for details about the use of this parameter on the different charging algorithms.

4.2.8 Battery float voltage

<i>Default value</i> 10V	<i>Range</i> 10...58V	<i>Resolution</i> 0.1V
<i>Unit</i> Volts	<i>LCD name</i> Bat. float U	<i>Modbus address</i> 0x1013

The maximum voltage applied to the battery once it's fully charged. See §3.1.3 for details about the use of this parameter on the different charging algorithms.

4.2.9 Battery low voltage

<i>Default value</i> 5V	<i>Range</i> 5...58V	<i>Resolution</i> 0.1V
<i>Unit</i> Volts	<i>LCD name</i> Bat. low U	<i>Modbus address</i> 0x1014

Threshold for "Battery low" alarm (§4.4.2.9).

4.2.10 Battery deep discharge voltage

<i>Default value</i> 5V	<i>Range</i> 5...58V	<i>Resolution</i> 0.1V
<i>Unit</i> Volts	<i>LCD name</i> Bat. deep disch. U	<i>Modbus address</i> 0x1015

Threshold for the "Battery deep discharged" alarm (§4.4.2.10).

4.2.11 Battery max. discharge current

<i>Default value</i> 21A	<i>Range</i> 5...21A	<i>Resolution</i> 0.1A
<i>Unit</i> Amperes	<i>LCD name</i> Bat. max. disch. I	<i>Modbus address</i> 0x1016

During backup the DCW20 limits the maximum discharge current to this value reducing the output voltage if necessary.

4.2.12 Battery capacity - Supercap capacitance

<i>Default value</i> 1Ah or 1F	<i>Range</i> 1...1000Ah or F	<i>Resolution</i> 0.1Ah or F
<i>Unit</i> Ampere hours or Farad	<i>LCD name</i> Bat. capacity	<i>Modbus address</i> 0x1017

Nominal capacity (Ah) of the installed battery or capacitance (F) in case a Supercapacitor is installed. This parameter is used to calculate the battery State of Charge (SoC) during charge and discharge.

4.2.13 Battery min. temperature

<i>Default value</i> -40°C	<i>Range</i> -40...60°C	<i>Resolution</i> 1°C
<i>Unit</i> Celsius	<i>LCD name</i> Bat. min. T	<i>Modbus address</i> 0x1018

Threshold for the "Battery under temperature" alarm (§4.4.2.3).

4.2.14 Battery max. temperature

Default value 60°C	Range -40...60°C	Resolution 1°C
Unit Degree Celsius	LCD name Bat. max. T	Modbus address 0x1019

Threshold for the “Battery over temperature” alarm (§4.4.2.4).

4.2.15 Battery lifetime

Default value 100kh	Range 1...100kh	Resolution 1kh
Unit Kilo hours	LCD name Bat. lifetime	Modbus address 0x101A

Threshold for the “Battery lifetime elapsed” alarm (§4.4.2.5).

4.2.16 Ri alarm mode

Default value Disabled	Values (Modbus value) Disabled (0), Fixed (1), Automatic (2), Auto. Done (3)	
Unit NA	LCD name Ri mode	Modbus address 0x101B

Mode of operation for the “Battery Ri too high” alarm (§4.4.2.2).

4.2.17 Ri nom.

Default value 1mΩ	Range 1...300mΩ	Resolution 0.1mΩ
Unit Milli ohm	LCD name Ri nominal	Modbus address 0x101C

Used for the threshold calculation of the “Battery Ri too high” alarm (§4.4.2.2).

4.2.18 Ri max. variation

Default value 300%	Range 50...300%	Resolution 1%
Unit Percent	LCD name Ri max. variation	Modbus address 0x101D

Used for the threshold calculation of the “Battery Ri too high” alarm (§4.4.2.2).

4.2.19 Operating mode

Default value UPS	Values (Modbus value) UPS (1), DC/DC (2)	
Unit NA	LCD name Operating mode	Modbus address 0x1020

Defines the DCW20 operating mode. See §3.1 and §3.2 for details of each mode.

4.2.20 Nominal output voltage

Default value 10V	Range 10...58V	Resolution 0.1V
Unit Volts	LCD name Output nominal U	Modbus address 0x1021

UPS mode: DCW20 enters backup mode when the output voltage drops below 90% of the nominal value, it is also the regulated output voltage during backup.

DC/DC mode: it corresponds to the regulated output voltage.

4.2.21 Max. input current

Default value 20A	Range 1...21A	Resolution 0.1A
Unit Amperes	LCD name Max input I	Modbus address 0x1022
<p>UPS mode: DCW20 limits the maximum input current to this value reducing the battery charging current if necessary.</p> <p>DC/DC mode: DCW20 limits the maximum input current (in DC/DC mode the input is connected to the battery connection) to this value reducing the output voltage if necessary.</p>		

4.2.22 Max. output current

Default value 20A	Range 5...21A	Resolution 0.1A
Unit Amperes	LCD name Max output I	Modbus address 0x1023
DCW20 limits the maximum output current to this value reducing the output voltage if necessary.		

4.2.23 Max. Backup time enable

Default value Disabled	Values (Modbus value) Disabled (0), Enabled (1)	
Unit NA	LCD name Backup time enable	Modbus address 0x1024
If enabled the DCW20 shuts down if the backup last more than the "Max. backup time" value (§4.2.24).		

4.2.24 Max. backup time

Default value 1440min	Range 1... 1440min	Resolution 1min
Unit Minutes	LCD name Back. time max	Modbus address 0x1025
If "Max. Backup time enable" field is enabled the DCW20 shuts down if the backup last more than the specified amount of time.		

4.2.25 Buzzer enable

Default value Disabled	Values (Modbus value) Disabled (0), Enabled (1)	
Unit NA	LCD name Buzzer enable	Modbus address 0x1026
Enable/Disable buzzer sound in case of alarm.		

4.2.26 Relay 1 configuration

Default value Normally open, Bat. life time, Bat. Ri too high, Bat. Charge failure	Flags (bit) Normally open (0), Backup (1), Soc < 25% (2), Bat. life time (3), Bat. Ri too high (4), Bat. Low (5), Bat. Disconnected (6), Bat. charge failure (7), Backup left < 25% (8), UPS not ready (9), UPS empty (10)	
Unit NA	LCD name Relay 1	Modbus address 0x1027

This field defines the behavior of relay 1 as follows:

Normally open	1 or more enabled state active?	Relay contact status
True	No	Open
True	Yes	Closed
False	No	Closed
False	Yes	Open

4.2.27 Relay 2 configuration

Default value Normally open, Backup	Flags (bit) Normally open (0), Backup (1), Soc < 25% (2), Bat. life time (3), Bat. Ri too high (4), Bat. Low (5), Bat. Disconnected (6), Bat. charge failure (7), Backup left < 25% (8), UPS not ready (9), UPS empty (10)	
Unit NA	LCD name Relay 2	Modbus address 0x1028

This field defines the behavior of relay 2 (see "Relay 1 configuration").

4.2.28 Inhibit polarity

Default value High	Values (Modbus value) Low (1), High (2)	
Unit NA	LCD name Inhibit polarity	Modbus address 0x1029

Selects the active polarity of the inhibit input. See §3.4 for more information about the inhibit function.

4.2.29 DC/DC output mode

Default value Single	Values (Modbus value) Single (1), Parallel (2)	
Unit NA	LCD name DC/DC out mode	Modbus address 0x102A

Select parallel mode in case the DCW20 is configure as DC/DC with output connected in parallel with another unit (§0).

4.2.30 Output enable

Default value Enabled	Values (Modbus value) Disabled (0), Enabled (1)	
Unit NA	LCD name Output enable	Modbus address 0x102B

Enable/Disable output.

4.2.31 Aux enable

Default value Enabled	Values (Modbus value) Disabled (0), Enabled (1)	
Unit NA	LCD name Aux enable	Modbus address 0x102C
Enable/Disable auxiliary output.		

4.2.32 Cold start on inhibit toggle

Default value Disabled	Values (Modbus value) Disabled (0), Enabled (1)	
Unit NA	LCD name CS on inhibit	Modbus address 0x102D
Enable/Disable the cold start on inhibit toggle as explained on §3.1.6.		

4.2.33 Cold start on battery connection

Default value Disabled	Values (Modbus value) Disabled (0), Enabled (1)	
Unit NA	LCD name CS on battery	Modbus address 0x102E
Enable/Disable the cold start on battery connection as explained on §3.1.6.		

4.2.34 PC shutdown enable

Default value Disabled	Values (Modbus value) Disabled (0), Enabled (1)	
Unit NA	LCD name PC shutdown enable	Modbus address 0x1030
See §3.1.5.		

4.2.35 PC automatic restart enable

Default value Disabled	Values (Modbus value) Disabled (0), Enabled (1)	
Unit NA	LCD name PC restart enable	Modbus address 0x1031
See §3.1.5.		

4.2.36 PC shutdown delay

Default value 3600s	Range 1...3600s	Resolution 1s
Unit Seconds	LCD name PC shutdown delay	Modbus address 0x1032
See §3.1.5.		

4.2.37 PC shutdown time

Default value 600s	Range 1...600s	Resolution 1s
Unit Seconds	LCD name PC shutdown time	Modbus address 0x1033
See §3.1.5.		

4.2.38 PC restart minimum time

Default value 1s	Range 1...60s	Resolution 1s
Unit Seconds	LCD name PC restart time	Modbus address 0x1034
See §3.1.5.		

4.2.39 PC off detection current threshold

Default value 0A	Range 0...20A	Resolution 0.1A
Unit Amperes	LCD name PC OFF I	Modbus address 0x1035
See §3.1.5.		

4.2.40 PC off detection timer

Default value 1s	Range 1...60s	Resolution 1s
Unit Seconds	LCD name PC OFF time	Modbus address 0x1036
See §3.1.5.		

4.2.41 Blink output on backup enable

Default value Disabled	Range Disabled (0), Enabled (1)	
Unit NA	LCD name Blink out enable	Modbus address 0x1040
See §3.1.7		

4.2.42 Blink output on backup Ton

Default value 10s	Range 10...600s	Resolution 1s
Unit Seconds	LCD name Blink out Ton	Modbus address 0x1041
See §3.1.7		

4.2.43 Blink output on backup Toff

Default value 0.2s	Range 0.1...60s	Resolution 0.1s
Unit Seconds	LCD name Blink out Toff	Modbus address 0x1042
See §3.1.7		

4.2.44 Output short circuit latch enable

Default value Disabled	Range Disabled (0), Enabled (1)	
Unit NA	LCD name Out SC latch enable	Modbus address 0x1043

When enable the device disables the output when a short circuit is detected on the output. To restart the output the operator must press the "OK" button from the front panel.

4.2.45 Output short circuit detection voltage threshold

Default value 3V	Range 3V...58V	Resolution 0.1V
Unit Volts	LCD name Out SC detection th.	Modbus address 0x1044
<p>By default the output short circuit is detected only if the residual voltage on the output pins is < 3V. In some application where long cables are connected to the output, if a short circuit is applied at the end of the cable, the residual voltage on the connector may be > 3V. In this case, increasing the detection threshold, ensures the short circuit is detected.</p>		

4.2.46 High inrush load enable

Default value Disabled	Range Disabled (0), Enabled (1)	
Unit NA	LCD name High inrush enable	Modbus address 0x1045
<p>When enable, the unit send a higher current pulse when the output is switched on, to withstand loads with a high start-up inrush current.</p>		

4.2.47 UPS not ready SoC threshold

Default value 90%	Range 10%...90%	Resolution 1%
Unit %	LCD name Not ready SoC th	Modbus address 0x1046
<p>Sets the State of Charge threshold for the UPS not ready signal.</p>		

4.2.48 UPS near empty SoC threshold

Default value 10%	Range 10%...90%	Resolution 1%
Unit %	LCD name Near empty SoC th	Modbus address 0x1047
<p>Sets the State of Charge threshold for the UPS near empty signal.</p>		

4.2.49 Lock settings

Default value Disabled	Range Disabled (0), Enabled (1)	
Unit NA	LCD name Lock Settings	Modbus address 0x1048
<p>When enabled, disables the possibility to modify any device setting through the device's SETTING menu apart itself. The shortcut for toggle the value of this field is keep pressed at the same time the \uparrow (Up) and \downarrow (Down) buttons for at least 3 seconds when you are into the SETTINGS menu.</p>		

4.2.50 Delayed device shutdown time

Default value 60	Range 1...600s	Resolution 1s
Unit Seconds	LCD name Delayed shdn time	Modbus address 0x1049
<p>Specifies the time delay between the shutdown command and its execution.</p>		

4.2.51 Delayed device reset time

Default value 60	Range 1...600s	Resolution 1s
Unit Seconds	LCD name Delayed reset time	Modbus address 0x104A
Specifies the time delay between the reset command and its execution.		

4.2.52 Backup start threshold

Default value 90	Range 80...95%	Resolution 1%
Unit %	LCD name Backup start th	Modbus address 0x104B
Specifies the input voltage, expressed as percentage of output nominal voltage, at which the backup starts.		

4.2.53 Battery cycle

Default value Disabled	Range Disabled (0), Enabled (1)	
Unit NA	LCD name Battery cycle	Modbus address 0x1050
When enabled the device schedules and activates an periodic battery discharge based on day of week, time, and periodicity.		

4.2.54 Battery cycle every

Default value 1 week	Range 1 ... 52 weeks	Resolution 1week
Unit weeks	LCD name Battery cycle every	Modbus address 0x1051
Periodicity in weeks of the battery cycle.		

4.2.55 Battery cycle day

Default value Disabled	Range Monday (1), Tuesday (2), Wednesday (3), Thursday (4), Friday (5), Saturday (6), Sunday(7)	
Unit NA	LCD name Battery cycle day	Modbus address 0x1052
Specifies on which day of the week the battery cycle should be performed.		

4.2.56 Battery cycle hour

Default value 6h	Range 0...23	Resolution 1h
Unit h	LCD name Battery cycle time	Modbus address 0x1053
Specifies at which hour of the day the battery cycle should be performed.		

4.2.57 Battery cycle minute

Default value 0min	Range 0...59min	Resolution 1min
Unit min	LCD name Battery cycle time	Modbus address 0x1054
Specifies at which minute of the hour the battery cycle should be performed.		

4.2.58 Battery cycle SoC threshold

Default value 75%	Range 0...90%	Resolution 1%
Unit %	LCD name Battery cycle SoC th	Modbus address 0x1055
Specifies at which state of charge the battery cycle must be stopped.		

4.2.59 Battery cycle time threshold

Default value 5	Range 1...1440min	Resolution 1 min
Unit min	LCD name Battery cycle time th	Modbus address 0x1056
Specifies after how many minutes from start the battery cycle must be stopped.		

4.2.60 Battery installation date

Default value 1st January 2000	Range from 1st January 2000 to 31st December 2099	
Unit NA	LCD name Bat. installation date	Modbus address 0x1100
This field is used to compute the battery lifetime. If the battery lifetime exceeds the “Battery lifetime” value (§4.2.15), the “Battery lifetime elapsed” alarm (§4.4.2.5) activates.		

4.2.61 Battery charge cycles

Default value 0	Range 0...65535	Resolution 1
Unit Cycles	LCD name Bat. charge cycles	Modbus address 0x1104
The value increments automatically at the end of a battery charge cycle.		

4.3 Info

While in the info menu, use the UP/DOWN KEY to navigate through the menu items. The fields are also accessible via Modbus at the specified address. Modbus device identification fields are read using function 43/13 (0x2B/0x0E) at the specified object id.

4.3.1 Firmware version

LCD name FW version	Modbus Device Identification Object Id 0x02
3.3 digit indicating the firmware major minor version	

4.3.2 Firmware subversion

LCD name FW subversion	Modbus Device Identification Object Id 0x80
3 digit indicating the firmware subversion.	

4.3.3 Build date

LCD name Build date	Modbus Device Identification Object Id 0x82
Firmware build date.	

4.3.4 Build time

<i>LCD name</i> Build time	<i>Modbus</i> Device Identification Object Id 0x83
Firmware build time.	

4.3.5 Serial number

<i>LCD name</i> S/N	<i>Modbus</i> Device Identification Object Id 0x81
Device serial number.	

4.3.6 Boot cycles

<i>Unit</i> Cycles	<i>LCD name</i> Boot cycles	<i>Modbus address</i> 0x2010
Counter of power ON cycles.		

4.3.7 Operating time

<i>Unit</i> Hours	<i>LCD name</i> Operating time	<i>Modbus address</i> 0x2020
DCW20 operating hour counter.		

4.3.8 Battery operating time

<i>Unit</i> Hours	<i>LCD name</i> Bat. operating time	<i>Modbus address</i> 0x2022
Hours elapsed since the "Battery installation date" (§4.2.60).		

4.3.9 Next battery cycle

<i>LCD name</i> Next battery cycle	<i>Modbus</i> None
Information about next battery cycle	
<ul style="list-style-type: none"> • Date: Date and time of next scheduled battery cycle • Cycle disabled: The battery cycle function is disabled • In progress: The battery cycle is in progress 	

4.4 Logs

Every event is logged in the device FLASH memory. From the log menu the user can view their history. Use the UP/DOWN KEYS to navigate between logs, 2 logs are visible simultaneously on the LCD.

1	10h58m14s710ms	
	18/08/2016	
	Backup	
	0	
3	10h58m07s641ms	2
	18/08/2016	
	In under volt.	
4	1	5
		21.6V

1. **Time:** time at which the log occurred.
2. **Date:** date at which the log occurred.
3. **Name:** unique log name
4. **Primary value:** optional, see below for details.
5. **Secondary value:** optional, see below for details.

Table 6: Log screen

Logs are of 3 different kinds: **info**, **alarms** and **events**. All info and alarms have an associated Modbus field representing the current status (0 if inactive or 1 if active). For info and alarms a log is generated at each status transaction. In case of active alarm, the front LED and the buzzer turn ON.

4.4.1 Info

4.4.1.1 Battery charging	
LCD name	Modbus address
Bat charging	0x4000
Value1	Value2
Inactive (0), Active (1)	Not used
Active when the battery is charging.	
4.4.1.2 Battery floating	
LCD name	Modbus address
Bat floating	0x4001
Value1	Value2
Inactive (0), Active (1)	Not used
Active when the battery is fully charged.	
4.4.1.3 Battery discharging	
LCD name	Modbus address
Bat. discharging	0x4002
Value1	Value2
Inactive (0), Active (1)	Not used
Active when the battery is discharging.	
4.4.1.4 Battery cycle active	
LCD name	Modbus address
Battery cycle active	0x4003
Value1	Value2
Ended (0), Started (1)	Status 0 → 1: Battery voltage at battery cycle start
	Status 1 → 0: Minimum battery voltage during battery cycle
Active when a battery cycle is in progress.	

4.4.1.5 USB powered	
<i>LCD name</i> USB powered	<i>Modbus address</i> 0x4020
<i>Value1</i> Inactive (0), Active (1)	<i>Value2</i> Not used
DCW20 is powered by USB only.	

4.4.1.6 Cold start	
<i>LCD name</i> Cold start	<i>Modbus address</i> 0x4021
<i>Value1</i> Inactive (0), Active (1)	<i>Value2</i> Not used
DCW20 has powered ON through cold start (see §3.1.6).	

4.4.1.7 PC shutdown	
<i>LCD name</i> PC shutdown	<i>Modbus address</i> 0x4022
<i>Value1</i> Inactive (0), Active (1)	<i>Value2</i> Not used
Command to shutdowns the PC (see §3.1.5).	

4.4.1.8 PC power off	
<i>LCD name</i> PC power OFF	<i>Modbus address</i> 0x4023
<i>Value1</i> Inactive (0), Active (1)	<i>Value2</i> Not used
Command to power OFF the PC (see §3.1.5), DCW20 output switches OFF.	

4.4.1.9 External temperature sensor presence	
<i>LCD name</i> Ext. T sensor presence	<i>Modbus address</i> 0x4024
<i>Value1</i> Inactive (0), Active (1)	<i>Value2</i> Not used
Active if the optional external temperature sensor is connected.	

4.4.1.10 Inhibit	
<i>LCD name</i> Inhibit	<i>Modbus address</i> 0x4025
<i>Value1</i> Inactive (0), Active (1)	<i>Value2</i> Not used
Active if the inhibit input signal is asserted (see §3.4).	

4.4.1.11 Output disabled	
<i>LCD name</i> Output disabled	<i>Modbus address</i> 0x4026
<i>Value1</i> Inactive (0), Active (1)	<i>Value2</i> Not used
Active if the output is disabled in settings.	

4.4.1.12 Auxiliary output disabled	
<i>LCD name</i> Aux disabled	<i>Modbus address</i> 0x4027
<i>Value1</i> Inactive (0), Active (1)	<i>Value2</i> Not used
Active if the auxiliary output is disabled in settings.	

4.4.2 Alarms

4.4.2.1 Battery disconnected	
LCD name Bat. disconnected	Modbus address 0x4010
Value1 Inactive (0), Active (1)	Value2 Not used
Active when no battery is detected by DCW20. The detection of the battery disconnection can take up to 40s when the battery is in charging state and up to 20s when the battery is in float state.	
4.4.2.2 Battery Ri too high	
LCD name Bat. Ri too high	Modbus address 0x4011
Value1 Inactive (0), Active (1)	Value2 (Milli ohm) Status 0 → 1: Offending threshold Status 1 → 0: Max. measured value
Active when measured battery internal resistance exceed the alarm threshold (see §3.1.2)	
4.4.2.3 Battery under temperature	
LCD name Bat. under temperature	Modbus address 0x4012
Value1 Inactive (0), Active (1)	Value2 (Degree Celsius) Status 0 → 1: Offending threshold Status 1 → 0: Min. measured value
Active when the battery measured temperature (using the optional external sensor) is under the threshold specified in “ <i>Battery min. temperature</i> ” field (§4.2.13). If active the battery charged is disabled.	
4.4.2.4 Battery over temperature	
LCD name Bat. over temperature	Modbus address 0x4013
Value1 Inactive (0), Active (1)	Value2 (Degree Celsius) Status 0 → 1: Offending threshold Status 1 → 0: Max. measured value
Active when the battery measured temperature (using the optional external sensor) exceed the threshold specified in “ <i>Battery max. temperature</i> ” field (§4.2.14). If active the battery charged is disabled.	
4.4.2.5 Battery lifetime elapsed	
LCD name Bat. lifetime elapsed	Modbus address 0x4014
Value1 Inactive (0), Active (1)	Value2 (Hours) Status 0 → 1: Offending threshold Status 1 → 0: Max. calculated value
Active when the actual calculated battery lifetime exceeds the threshold specified in “ <i>Battery lifetime</i> ” field (§4.2.15).	
4.4.2.6 Battery charge failure	
LCD name Bat. charge fail	Modbus address 0x4015
Value1 Inactive (0), Active (1)	Value2 Not used
Active when DCW20 could not charge the battery correctly. When active, the battery charger is disabled. Disconnect the battery to reset the alarm.	

4.4.2.7 Battery SoC < 25%	
<i>LCD name</i> Bat. SoC < 25%	<i>Modbus address</i> 0x4016
<i>Value1</i> Inactive (0), Active (1)	<i>Value2</i> Not used
Active when the battery State of Charge is under 25% of the nominal full charge capacity.	

4.4.2.8 Battery over discharge current	
<i>LCD name</i> Bat. over discharge I	<i>Modbus address</i> 0x4017
<i>Value1</i> Inactive (0), Active (1)	<i>Value2 (Amperes)</i> Status 0 → 1: Offending threshold Status 1 → 0: Max. measured value
Active when the measured battery discharge current reaches the threshold specified in “Battery max. discharge current” field (§4.2.11).	

4.4.2.9 Battery low	
<i>LCD name:</i> Bat. low	<i>Modbus address</i> 0x4018
<i>Value1</i> Inactive (0), Active (1)	<i>Value2 (Volts)</i> Status 0 → 1: Offending threshold Status 1 → 0: Min. measured value
Active when the measured battery voltage is under the threshold specified in “Battery low voltage” field (§4.2.9).	

4.4.2.10 Battery deep discharged	
<i>LCD name</i> Bat. deep discharge	<i>Modbus address</i> 0x4019
<i>Value1</i> Inactive (0), Active (1)	<i>Value2 (Volts)</i> Status 0 → 1: Offending threshold Status 1 → 0: Min. measured value
Active when the battery measured voltage is under the threshold specified in “Battery deep discharge voltage” field (§4.2.10).	

4.4.2.11 Backup	
<i>LCD name</i> Backup	<i>Modbus address</i> 0x4030
<i>Value1</i> Inactive (0), Active (1)	<i>Value2</i> Not used
Active when the system is in backup (§3.1.1).	

4.4.2.12 Input under voltage	
<i>LCD name</i> Input under voltage	<i>Modbus address</i> 0x4031
<i>Value1</i> Inactive (0), Active (1)	<i>Value2 (Volts)</i> Status 0 → 1: Offending threshold Status 1 → 0: Min. measured value
Active when the measured input voltage is under 90% of the “Nominal output voltage” field (§4.2.20).	

4.4.2.13 Input over voltage	
<i>LCD name</i> Input over voltage	<i>Modbus address</i> 0x4032
<i>Value1</i> Inactive (0), Active (1)	<i>Value2 (Volts)</i> Status 0 → 1: Offending threshold Status 1 → 0: Max. measured value
Active when the measured input voltage exceeds 120% of the “Nominal output voltage” field (§4.2.20).	

4.4.2.14 Output under voltage	
<i>LCD name</i> Output under voltage	<i>Modbus address</i> 0x4033
<i>Value1</i> Inactive (0), Active (1)	<i>Value2 (Volts)</i> Status 0 → 1: Offending threshold Status 1 → 0: Min. measured value
Active when the measured output voltage is under 90% of the “Nominal output voltage” field (§4.2.20).	

4.4.2.15 Output over voltage	
<i>LCD name</i> Output over voltage	<i>Modbus address</i> 0x4034
<i>Value1</i> Inactive (0), Active (1)	<i>Value2 (Volts)</i> Status 0 → 1: Offending threshold Status 1 → 0: Max. measured value
Active when the measured output voltage exceeds 120% of the “Nominal output voltage” field (§4.2.20).	

4.4.2.16 Output overload	
<i>LCD name</i> Output overload	<i>Modbus address</i> 0x4035
<i>Value1</i> Inactive (0), Active (1)	<i>Value2</i> Not used
Active when the measured output current reaches the threshold specified in “Max. output current” field (§4.2.22).	

4.4.2.17 Input over current	
<i>LCD name</i> Input over current	<i>Modbus address</i> 0x4036
<i>Value1</i> Inactive (0), Active (1)	<i>Value2</i> Not used
Active when the measured input current reaches the threshold specified in “Max. input current” field (§4.2.21).	

4.4.2.18 Auxiliary output overload	
<i>LCD name</i> Aux overload	<i>Modbus address</i> 0x4037
<i>Value1</i> Inactive (0), Active (1)	<i>Value2</i> Not used
Active when an excessive load is detected on the auxiliary output.	

4.4.2.19 External temperature sensor error	
<i>LCD name</i> Ext. T sensor error	<i>Modbus address</i> 0x4038
<i>Value1</i> Inactive (0), Active (1)	<i>Value2</i> Not used
Active when the external temperature sensor is not connected while it's use is mandatory like in NiMh battery charging.	

4.4.2.20 Backup time left < 25%	
<i>LCD name</i> Backup time left < 25%	<i>Modbus address</i> 0x4039
<i>Value1</i> Inactive (0), Active (1)	<i>Value2</i> Not used
Active when the system is in backup and the maximal backup time is less than the “Max. backup time” filed (§4.2.2427).	

4.4.2.21 Warning over temperature	
<i>LCD name</i> Warn. over temperature	<i>Modbus address</i> 0x403A
<i>Value1</i> Inactive (0), Active (1)	<i>Value2</i> Not used
Active when the internal temperature is high. If the temperature increases more the device may switch OFF.	

4.4.2.22 Error over temperature	
<i>LCD name</i> Error over temperature	<i>Modbus address</i> 0x403B
<i>Value1</i> Inactive (0), Active (1)	<i>Value2</i> Not used
Active when the internal temperature is too high. To prevent damage the device switches OFF.	

4.4.2.23 Output short circuit	
<i>LCD name</i> Output short circuit	<i>Modbus address</i> 0x403C
<i>Value1</i> Inactive (0), Active (1)	<i>Value2</i> Not used
Active when a short circuit is detected on the output.	

4.4.2.24 Internal failure	
<i>LCD name</i> Internal failure	<i>Modbus address</i> 0x403D
<i>Value1</i> Inactive (0), Active (1)	<i>Value2</i> Internal fail code
Active when an internal failure is detected.	

4.4.3 Events

4.4.3.1 Power ON event	
<i>LCD name</i> Power ON	<i>Modbus address</i> 0xE000
<i>Value1</i> Power ON count	<i>Value2</i> Not used
Generated at every time the DCW20 is turned ON.	

4.4.3.2 Shutdown event	
<i>LCD name</i> Shutdown	<i>Modbus address</i> 0xE001
<i>Value1</i> Shutdown count	<i>Value2</i> Shutdown reason: 1 - Deep discharge 2 - Max. backup time elapsed 3 - Shutdown command 4 - Reset command 5 - Inhibit signal 6 - Power down
Generated at every time the DCW20 is turned OFF.	

4.4.3.3 Battery cycle triggered by	
<i>LCD name</i> Bat. cycle triggered by	<i>Modbus address</i> 0xE002
<i>Value1</i> Schedule (0), User (1)	<i>Value2</i> Not used
Schedule (0) if the battery cycle is started automatically on scheduled date/time, User (1) if the battery cycle is started by user.	

4.4.3.4 Battery cycle ended by	
<i>LCD name</i> Bat. cycle ended by	<i>Modbus address</i> 0xE003
<i>Value1</i> State of charge (1), Time limit (2), Input UV (3), Battery in charge (4), User (5)	<i>Value2</i> Not used
Specifies the cause/reason of battery cycle ending <ul style="list-style-type: none"> • State of charge: Battery cycle ended at specified state of charge • Time limit: Battery cycle ended after specified time • Input UV: Battery cycle end caused by the input under voltage • Battery in charge: Battery cycle ended because the battery was charging • User: Battery cycle stopped by user 	

4.5 Wizard

The wizard assists the user during the DCW20 configuration. It should be run once at commissioning.

5 Technical Specifications

See DCW20 datasheet available on www.nextys.com.

6 Installation procedure

See DCW20 short form installation manual, available on www.nextys.com, for information related to installation procedure.