

NDW240

240W Universal, Isolated DC/DC

User Manual



DISCLAIMER

TDK-Lambda Switzerland SA reserves the right to make changes without further notice to any products herein.

TDK-Lambda Switzerland SA makes no warranty, representation or guarantee regarding the suitability of its products for any particular purpose, nor does *TDK-Lambda Switzerland SA* assume any liability arising out of the application or use of any product, and specifically disclaims any and all liability, including without limitation consequential or incidental damages. "Typical" parameters which may be provided in *TDK-Lambda Switzerland SA* data sheets and/or specifications can and do vary in different applications and actual performance may vary overtime.

All operating parameters, including "Typicals", must be validated for each customer application by customer's technical experts. *TDK-Lambda Switzerland SA* does not convey any license under its patent rights nor the rights of others. *TDK-Lambda Switzerland SA* products are not designed, intended, or authorized for use as components in systems intended for surgical implant into the body, or other applications intended to support or sustain life, or for any other application in which the failure of the *TDK-Lambda Switzerland SA* product could create a situation where personal injury or death may occur. Should Buyer purchase or use *TDK-Lambda Switzerland SA* products for any such unintended or unauthorized application, Buyer shall indemnify and hold *TDK-Lambda Switzerland SA* and its officers, employees, subsidiaries, affiliates, and distributors harmless against all claims, costs, damages, and expenses, and reasonable attorney fees arising out of, directly or indirectly, any claim of personal injury or death associated with such unintended or unauthorized use, even if such claim alleges that *TDK-Lambda Switzerland SA* was negligent regarding the design or manufacture of the part.

The Customer should ensure that it has the most up to date version of the document by contacting its local *TDK-Lambda Switzerland SA* office. This document supersedes any earlier documentation relating to the products referred to herein. The information contained in this document is current at the date of publication. It may subsequently be updated, revised or withdrawn.

The Customer should ensure that *TDK-Lambda Switzerland SA* product uses the most up to date Software and Firmware provided on *TDK-Lambda Switzerland SA* website to ensure reliable operation of the system.

All Trade Marks recognized. Specifications and information herein are Subject to change without notice.

1	Product description	4
2	Features and benefits	5
3	Functional description	5
3.1	Operating mode	6
3.1.1	Single	6
3.1.2	Parallel	6
3.2	Output voltage programming	6
3.3	Current limitation	7
3.3.1	Hiccup	7
3.3.2	Constant current	7
3.4	Output enable	7
3.5	DC-OK Relay	7
3.6	Alarms	8
3.6.1	Output short circuit	8
3.6.2	Output overload	8
3.6.3	Over temperature warning	8
3.6.4	Over temperature error	8
3.6.5	USB power	8
3.6.6	Output over voltage	8
3.7	Modbus	9
4	User interface	10
4.1	Logs	11
4.1.1	DC-OK	11
4.1.2	Output disabled	11
4.1.3	Output short circuit	11
4.1.4	Output overload	12
4.1.5	USB powered	12
4.1.6	Over temperature warning	12
4.1.7	Over temperature error	12
4.1.8	Power ON event	12
5	Technical Specifications	12

1 Product description

⚠ Use latest device Documentation, Software and Firmware to ensure reliable operation of the system (downloadable from www.nextys.com).

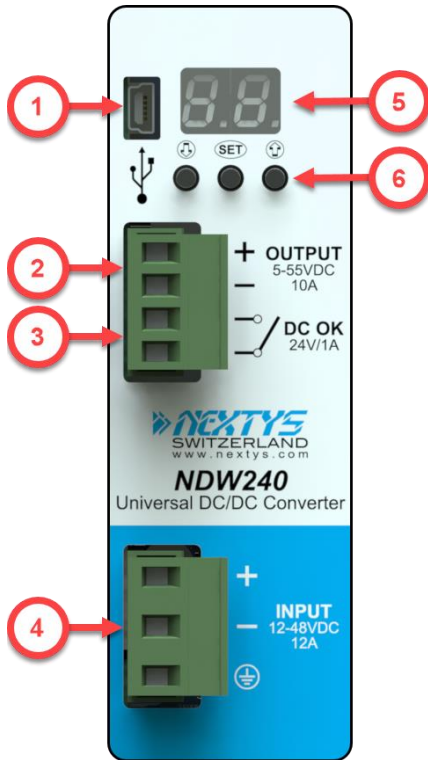

Figure 1: Front panel view

1. **Modbus over USB:** used to connect a device running POWERMASTER or custom application. Firmware update is also possible.
2. **DC Output:** connected to the load. The output voltage is adjustable between 5 to 55Vdc.
3. **DC-OK dry contact:** a normally open relay contact is available; the relay closes when the output voltage is >90% of the programmed output voltage value.
4. **DC Input:** input voltage supply, range is from 12 to 48Vdc.
5. **Display:** 2-digits LED display used to program the device and read its status.
6. **Control keys:** 3 push buttons are provided to navigate through menus and to select various functions.

2 Features and benefits

- Up to 240W output power (voltage dependent)
- Converts any voltage between 10.5V and 55V to any voltage between 5V and 55V
- High efficiency and compact size
- Constant current or hiccup mode limitation, user settable
- Digital Power regulation
- Isolated topology (4.2kVdc)
- Modbus over USB interface for control and monitoring
- Multiple protections integrated
- Parallelable for power or redundancy (integrated ORing circuitry)
- Suitable for POWERMASTER software (available for Windows and Android OS)

3 Functional description

NDW240 is a high performance digitally controlled isolated DC/DC converter. Its unique power stage architecture allows the device to operate over a very wide input and output voltage range keeping high energy conversion efficiency, high reliability and tough regulation characteristics.

To achieve these performances the NDW240 power stage is digitally controlled with an optimized switching algorithm. The system microprocessor allows the user to access to the various measurements and system status in real time.

NDW240 offers an integrated low loss ORing circuit to simplify the set-up of redundant power systems.

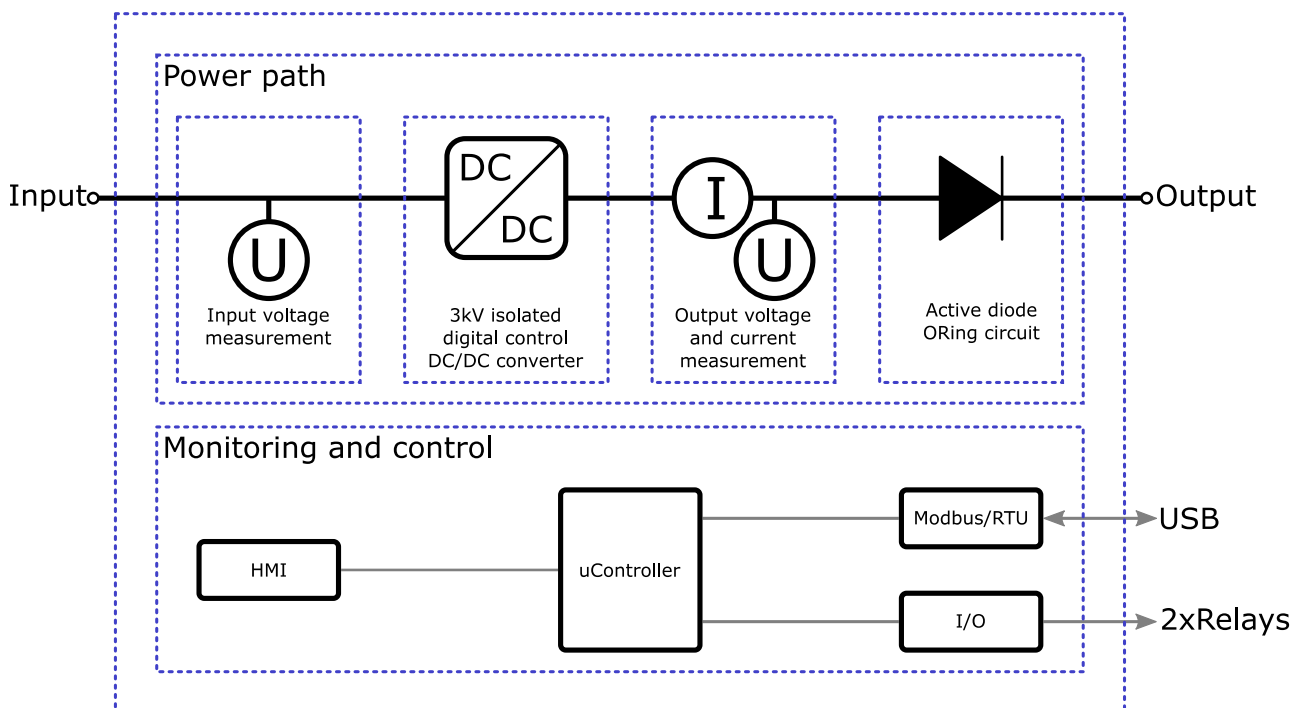

Figure 2: NDW240 simplified block diagram

3.1 Operating mode

3.1.1 Single

When the NDW240 is used as a single device powering the load the operating mode must be set to “Single (SI)”, see §4. Any voltage between 11VDC and 55VDC can be converted in any voltage between 5VDC and 55VDC with a maximum output power of 240W (see product datasheet for details).

3.1.2 Parallel

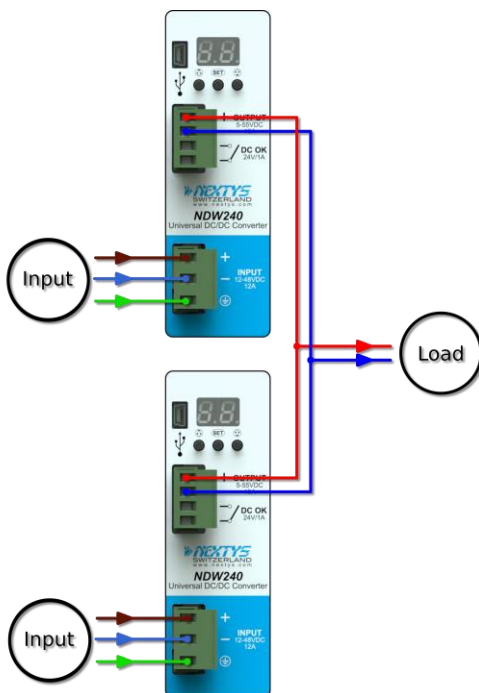

Figure 3: NDW240 parallel connection

Multiple NDW240 can be connected in parallel to increase the output power capabilities and/or for redundancy purposes.

When operating in this mode operating mode must be set to “Parallel (PA)”, see §4.

For proper operation between the units the cable length connecting the various NDW240 to the load must have the same length and cross-section.

For optimal current sharing it may be necessary to slightly adjust some of the devices output voltage until the same current is delivered by all the units.

For precise set-up of a parallel system a good precision current meter is suggested.

It is recommended to limit the load power to 80% of the sum of the individual output power of the paralleled units.

Note: when “Parallel (PA)” mode is selected the current limitation method is automatically fixed to “Constant Current (CC)” model.

3.2 Output voltage programming

NDW240 output voltage can be programmed over a range from 4.5V to 55V thanks to the “Output Voltage” menu item, see §4. The resolution is 10mV.

While setting the output voltage the screen cycles between integer part (with dot point on) and cents of volts every 3sec. For example, if the value 24.56 is set the screen cycles between the following two screens:

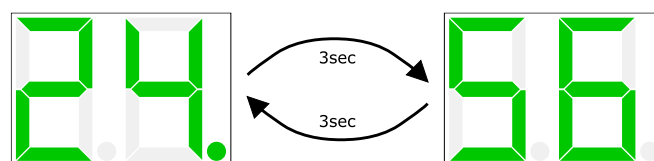

Figure 4: Example of 24.56V setting value shown on display

3.3 Current limitation

NDW240 can be set-up with 2 different current limitation algorithms, depending on application. The maximum current delivered by the device can be limited thanks to the “Output Current (IO)” menu. The maximum output current (I_{max}) can be limited from 1A to 11A (default 10A) through this menu, see §4. Once the load asks for more current than the programmed I_{max} the device goes into current limitation mode; two limitation algorithms are selectable by the user, see §3.3.1 and §3.3.2 for details.

⚠ To self-protect, the device never delivers higher current than the one specified on the datasheet “Output power limitation curve” and “Output current limitation curve” charts. This regardless of the I_{max} setting value.

3.3.1 Hiccup

When NDW240 is set up in “Hiccup mode (HU)” the output current is limited at **1.5x I_{max}** . When the programmed I_{max} value is exceeded a timer is started. If the load current demand is not reduced below I_{max} within 5 seconds the output is switched off for 10 seconds.

Overload (OL) error message is shown on the display, see §3.6 details. This cycle is then repeated until the load current demand is not decreased below I_{max} .

This operating mode is recommended when powering loads requiring high inrush current demands.

In case of a direct short circuit on the output the output is switched off in about 0.2 seconds and kept off for 10 seconds. Short Circuit (SC) error message is shown on the display, see §3.6 details. This cycle is then repeated until the short circuit is removed.

Note: when “Parallel (PA)” mode is selected the current limitation method is automatically fixed to “Constant Current (CC)” model and it is not possible to select “Hiccup mode” when “Parallel mode” is selected.

3.3.2 Constant current

When NDW240 is set up in “Constant Current (CC)” the output current is limited at I_{max} . If the load asks for more current than I_{max} the output voltage is progressively decreased to keep the output current regulated at I_{max} . When the output voltage decreases below 90% of the programmed output voltage the “DC-OK” relay dry contact opens see §3.5, informing the user that the output voltage is no more regulated.

This operating mode is recommended when powering highly capacitive loads. In case of a direct short circuit on the output the output is switched off in about 0.2 seconds and kept off for 10 seconds. Short Circuit (SC) error message is shown on the display, see §3.6 details. This cycle is then repeated until the short circuit is removed.

3.4 Output enable

The NDW240 is provided with a software control allowing to switching ON and OFF the output of the device. This flag is available at Modbus address 0x1014, see §3.7 for details.

3.5 DC-OK Relay

A normally open relay is used to indicate that the output voltage is available and regulated. If the output voltage drops below 90% of the programmed output voltage value.

3.6 Alarms

3.6.1 Output short circuit

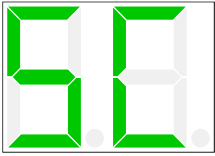

The “Short Circuit (SC)” error message appears when a short circuit is detected at the output.
In this case the output is switched off and then restarted after 10 seconds. This cycle is repeated until the short circuit is removed.

3.6.2 Output overload

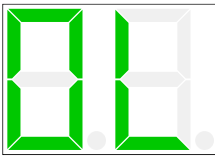

The “Overload (OL)” error message appears when the output current exceeds I_{max} ; it is only applicable when “hiccup mode” current limitation is selected.
In this case the output is switched off after 5 seconds of continuous overload and then restarted after 10 seconds. This cycle is repeated until the output current is reduced below I_{max} .

3.6.3 Over temperature warning

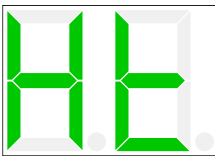

The “Over Temperature warning (Ht)” appears when the internal temperature is reaching unusually high levels. If no modification of the ambient operating temperature and / or load conditions is performed by the user, it is highly possible that an “Over Temperature (Ot)” error occurs, leading to the output switch off.

3.6.4 Over temperature error

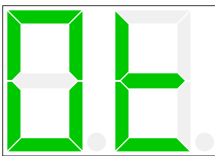

The “Over Temperature (Ot)” error message appears when the internal temperature exceeds the safe limits. In this case the output is switched off. The output is switched back on when the temperature decreased to safe limits. In case of repeated Over Temperature errors check the device ventilation and/or reduce ambient temperature

3.6.5 USB power

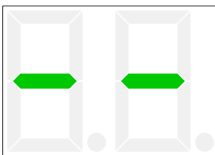

When the device is only connected to a USB device with no input voltage applied this information is shown on the display. The output is switched off but the user can however configure the device parameters and / or update the firmware.

3.6.6 Output over voltage

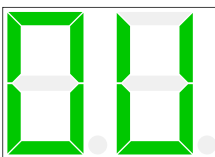

In case of an internal DC/DC converter defect, if the measured voltage exceeds the set voltage of 15% the output is shut down and the alarm signaled.

3.7 Modbus

NDW240 communicates through Modbus/RTU as specified on “[MODBUS over Serial Line](#)” and “[MODBUS APPLICATION PROTOCOL SPECIFICATION](#)” documents available on <http://www.modbus.org/>.

Table 1 contains the field types and Table 2 the mapped fields.

Type	Modbus function codes		Description
	Read	Write	
BIT	1,2	5,15	Single bit with value 0 or 1
SINT16	3,4	6,16	Signed 16 bit value (2's complement)
UINT16	3,4	6,16	Unsigned 16 bit value

Table 1: Modbus types

Address	Type	R/W	Unit	Min.	Max.	Description
<i>Settings</i>						
0x1000	UINT16	R/W	1	1	99	Modbus address.
0x1010	UINT16	R/W	0.01	4.5	57	Nominal output voltage [V].
0x1011	UINT16	R/W	0.1	1	11	Maximal output current [A].
0x1012	UINT16	R/W	1	1	2	Operating mode (§3.1): 1. Single 2. Parallel
0x1013	UINT16	R/W	1	1	2	Current limitation (§3.2): 1. Hiccup 2. Constant current
0x1014	UINT16	R/W	1	0	1	Output enable. 0: Disabled 1: Enabled
0x1015	UINT16	R/W	1	0	1	Lock settings. 0: Disabled 1: Enabled
<i>Metering</i>						
0x2000	SINT16	R	0.1V	0	60	Output voltage [V].
0x2001	SINT16	R	0.1V	0	15	Output current [A].
0x2002	SINT16	R	0.1V	0	360	Output power [W].
0x2003	SINT16	R	0.1V	0	60	Input voltage [V].
<i>State</i>						
0x4000	BIT	R	1	0	1	DC OK
0x4001	BIT	R	1	0	1	Output disabled.
0x4002	BIT	R	1	0	1	Output short circuit.
0x4003	BIT	R	1	0	1	Output overload.
0x4004	BIT	R	1	0	1	USB powered.
0x4005	BIT	R	1	0	1	Over temperature warning.
0x4006	BIT	R	1	0	1	Over temperature error.
0x4007	BIT	R	1	0	1	Output over voltage error.

Table 2: Modbus fields

4 User interface

The NDW240 is provided with a 2-digits 7-segments LED display used to indicate the status and to navigate through the configuration menus. During normal operation, the measures are reported. Alarms are also reported on the display.

The layout of the menu is shown below. The various options are selected with the 3 keys.

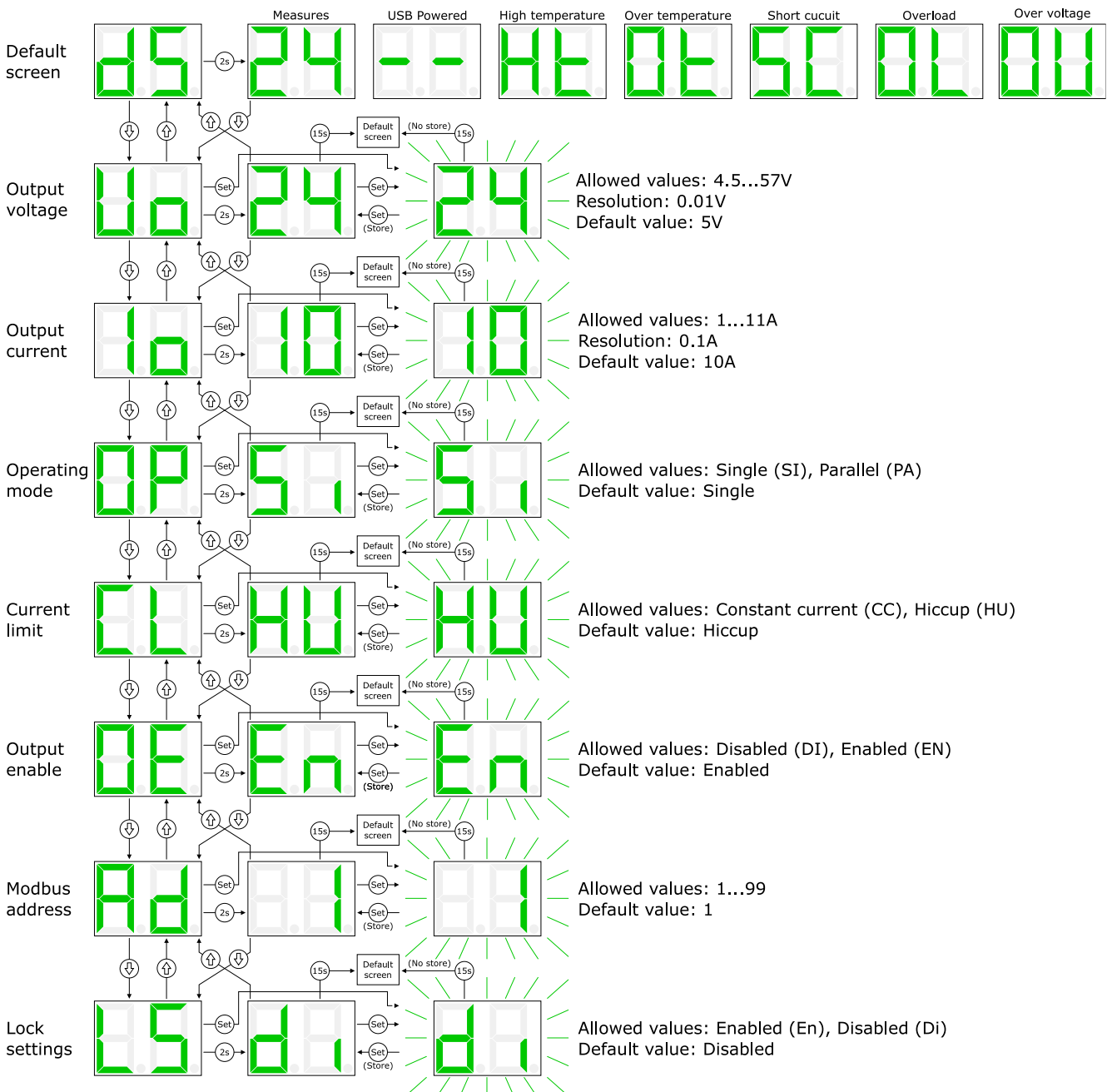

Figure 5: HMI

User can select the measure to show on the display pressing the set button as shown beside.

The 3 available measures are:

- Output voltage
- Output current
- Input voltage

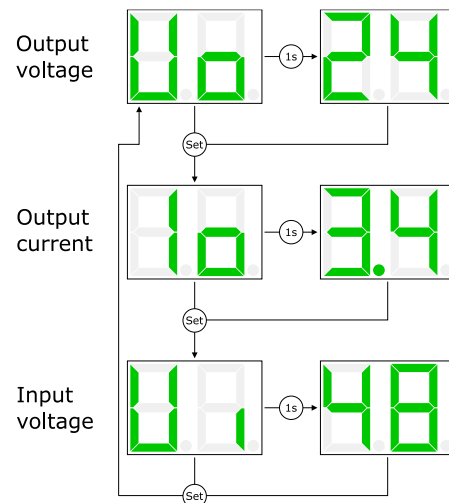

Figure 6: HMI measures

The locking/unlocking of the settings editing can be done using the field “Lock settings” (*LS*) field into the “User Interface” menu (§4) or through the Modbus “Lock settings” field.

The locking/unlocking of the settings editing can also be done keeping pressed simultaneously the ↑ (Up) and ↓ (Down) buttons for at least 3 seconds. There are no notifications using this procedure.

When the lock is active, trying to edit a parameter using the device’s buttons shows a “SL” (Settings Locked) message for a couple of seconds. It is always possible to edit the setting through Modbus regardless the status of the lock.

4.1 Logs

NDW240 stores important log information on flash memory. Logs are readable using the free POWERMASTER application.

4.1.1 DC-OK

Modbus address

0x4000

Value1

Inactive (0), Active (1)

Value2

Not used

Active when the measured output voltage exceeds the 90% of the nominal output voltage.

4.1.2 Output disabled

Modbus address

0x4001

Value1

Inactive (0), Active (1)

Value2

Not used

Active when the output is disabled through the Modbus settings.

4.1.3 Output short circuit

Modbus address

0x4002

Value1

Inactive (0), Active (1)

Value2

Not used

Active when the output is short circuited.

4.1.4 Output overload	
<i>Modbus address</i> 0x4003	
<i>Value1</i> Inactive (0), Active (1)	<i>Value2</i> Not used
Active when the output is overloaded.	

4.1.5 USB powered	
<i>Modbus address</i> 0x4004	
<i>Value1</i> Inactive (0), Active (1)	<i>Value2</i> Not used
Active when the unit is powered by USB only.	

4.1.6 Over temperature warning	
<i>Modbus address</i> 0x4005	
<i>Value1</i> Inactive (0), Active (1)	<i>Value2</i> Not used
Active when the internal temperature is high. If the temperature increases more the device may switch OFF.	

4.1.7 Over temperature error	
<i>Modbus address</i> 0x4006	
<i>Value1</i> Inactive (0), Active (1)	<i>Value2</i> Not used
Active when the internal temperature is too high. To prevent damage the device switches OFF.	

4.1.8 Power ON event	
<i>Modbus address</i> 0xE000	
<i>Value1</i> Power ON count.	<i>Value2</i> Not used
Generated at every time the NDW240 is turned ON.	

5 Technical Specifications

See NDW240 datasheet available on www.nextys.com.