

BATTMASTER®

Advanced Wireless Battery Monitoring System

Datasheet



1 General description

BATTMASTER® is a wireless battery monitoring system that measures and logs the voltage, internal resistance, temperature and current of lead acid batteries (2, 6 or 12 V nominal voltage) as individual blocks or within a battery string. It can operate as a standalone system or in conjunction with a PC/LAN. The modular architecture of the system has the benefit to be easily customizable to log other parameters on request (i.e. pressure, humidity, etc.).

BATTMASTER® is composed of 4 components:

CU (Central Unit): collects and stores the DAM and IDAM data, manages the communication with the PC and sends SMS/E-Mail notifications.



Figure 1: CU

DAM (Data Acquisition Module): measures the voltage, temperature and internal resistance of the battery and stores the most significant data until the next reading by the CU. All data are time stamped.

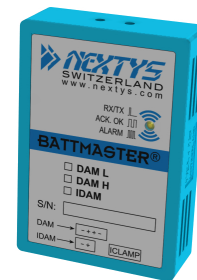


Figure 2: DAM

IDAM (Current Acquisition Module): measures the current of a battery or a string of batteries, in conjunction with a Hall effect current clamp (factory provided). It stores the most significant data until the next reading by the CU. All data are time stamped.



Figure 3: IDAM

BATTMASTER® Application Software: Used to configure and monitor the system using an USB or Ethernet connection. It consists of a user friendly GUI (Graphical User Interface), a database (DB) and a communication module.

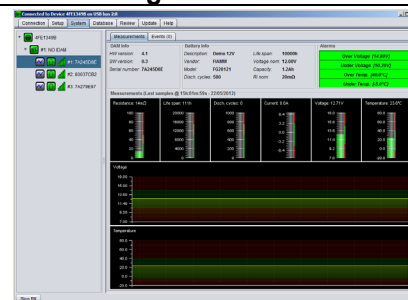


Figure 4: Application screen

A typical system is composed by one **CU**, one **IDAM** for each string of batteries and one **DAM** for each battery. A simple system composed of one single string of batteries is shown below. Each **CU** supports up to **1024 (50 for lite version) DAMs** and **64 IDAMs**.









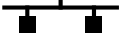
	CU		IDAM		DAM
	Battery		PC		Mobile phone
	RF link		USB		10/100Mb Ethernet

Table 1: Symbols legend

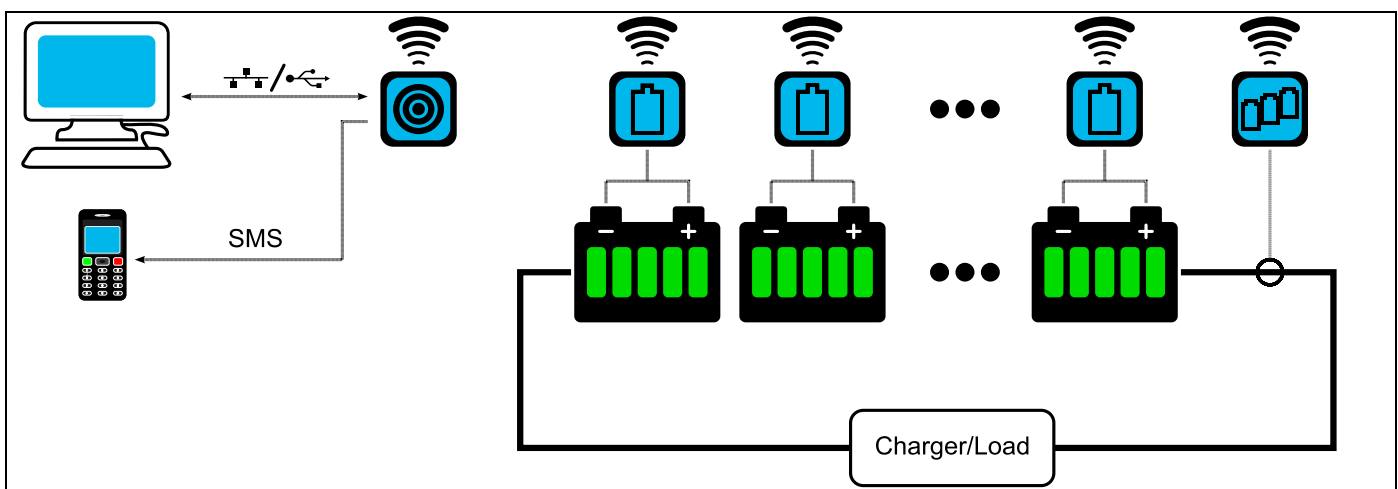


Figure 5: Typical configuration

2 Features and benefits

- Increased safety and reliability for critical application
- Reduction of maintenance costs
- Increased battery lifespan
- Commodity (ease) of installation and operation
- Possible integration with other systems
- Ethernet and Modbus/TCP connectivity allows remote monitoring
- Automatic SMS and E-Mail notifications
- Customizable for other parameters logging (i.e. pressure, humidity,...)

3 Functional description

Each **DAM** measures the voltage and temperature of the battery with a sampling rate of 10 ms. All significant data (minimum, maximum, average voltage and temperature, last R_i measured value, discharge cycles and out of limit voltage, temperature alarms) are stored in the DAM memory and transmitted to the **CU** when required.

The **IDAM** (optional) measures the current of the battery (or string of batteries) and the discharge cycles. The **CU** downloads every **DAM's** stored data with a user settable *Acquisition Interval (AI)* on a μ SD card. After downloading the data, the **DAMs** memory is erased and a new set of data is built for the following request.

The Acquisition Interval represents the time between 2 scans of the **DAMs** modules by the **CU**. The minimum recommended value for *AI* is 1h, because the batteries are slowly changing systems and there is no need of overloading the database with repetitive information. The minimum *AI* value is limited automatically by the system in proportion with the number of batteries. The system guarantees that no significant data will be lost, independently of the *AI* value.

Ri Sampling Interval represents the time between 2 R_i measures. R_i measures starts only if the specific battery is not in an alarm status.

The user can configure the system to automatically send *E-Mail* and *SMS notification* in case of an alarm or event. Up to **2 E-Mail addresses** and **3 cell phones numbers** for SMS can be configured.

By using the **BATTMASTER®** software it is possible to view the actual system status/measures as well as retrieve the data collected on the μ SD card for further analysis.

Modbus/TCP communication allows integration with other systems.

Various zoom/pan operations and user settable graphical parameters are possible.

Exporting the data in various graphical or spreadsheet formats is possible.

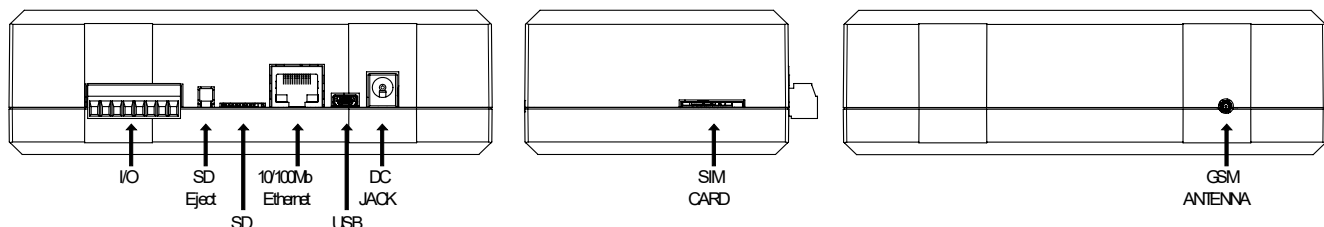


Figure 6: CU connectors

4 Dimensions

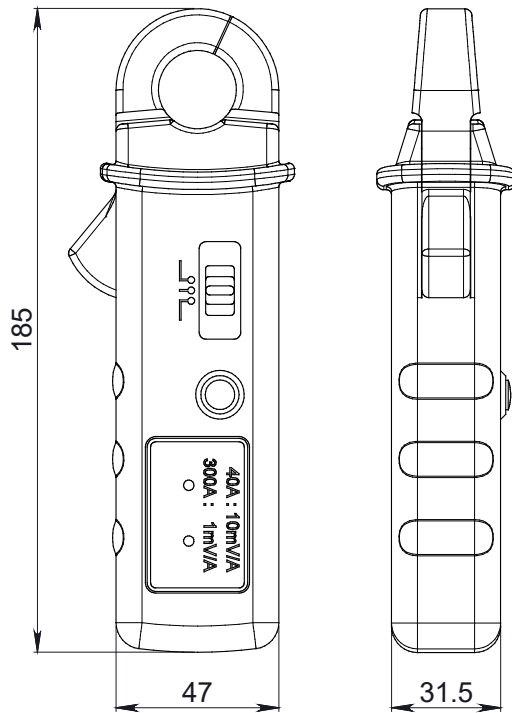


Figure 7: 300A current clamp

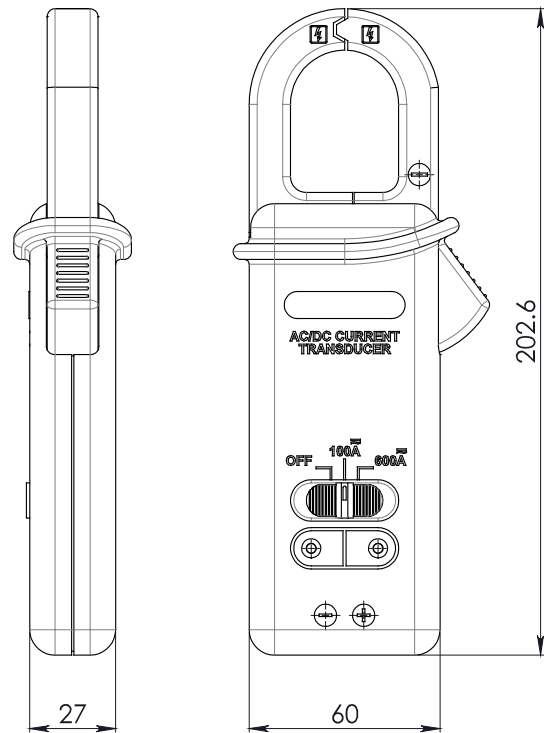


Figure 8: 600A current clamp

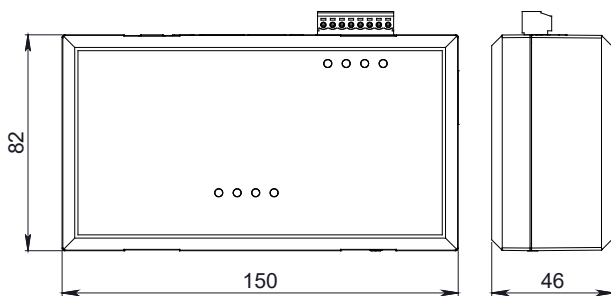


Figure 9: CU enclosure

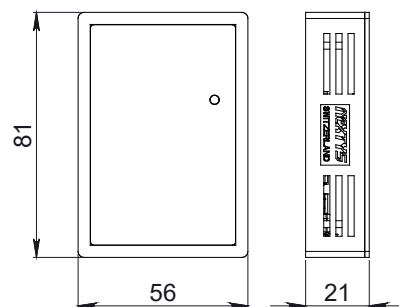


Figure 10: DAM - IDAM enclosure

5 General Characteristics

CU			
Supply input voltage range	4.5...5.5VDC by external power supply or by USB		
Current consumption	0.5A max.		
Weight	250g		
Plug-in AC adapter	- Input: 100..240Vac / 300mA, 50..60Hz - Output: 5Vdc / 1A		
Backup power	2X AAA NiMh rechargeable batteries (about 1.5h of backup)		
Digital inputs	- 2 x opto isolated, 5...30VDC, 10mA - Input 1: when active Real Time Logging enables - Input 2: available for future use		
Digital outputs	- 2 x relays, 30VDC 3A max - Output 1: is closed if no alarm is ongoing, open otherwise - Output 2: available for future expansion		
Data storage	FAT32 custom formatted microSD card, up to 4GB (> 2 years for 1000 batteries at refresh rate 0.5h)		
Max. number of devices	Full version	64 IDAM, 1024 DAM	
	Lite version	64 IDAM, 50 DAM	
Connectivity	Ethernet	- 10/100Mb - Used for remote configuration and monitoring - HTTP server and SMTP client	
	Modbus/TCP	- Remote Monitoring - Real Time Logging enable	
	USB2	- Full speed 12Mbit/s - Used for remote configuration and monitoring	
	GSM	- Quad-Band 850/900/1800/1900MHz - SMS alarms	
	RF	- 868.00-868.60MHz, Max EIRP 4mW, 3 channels user settable - Up to 100 meters outdoor, up to 30 meters indoor	
DAM			
L type (2V batteries)		H type (6/12V batteries)	
Battery voltage range	1.5...5.5VDC	5...18VDC	
Current consumption (typical)	80mA @ 2V (Sleep mode: 9mA)	30mA @ 12V (Sleep mode: 4mA)	
Weight	40g		
RF	- 868.00-868.60MHz, Max EIRP 4mW, 3 channels user settable - Up to 100 meters outdoor, up to 30 meters indoor		
Battery Measures	Voltage	1.5...5.5VDC, $\pm 1.5\%$	5...18V, $\pm 1.5\%$
	Ri	1...300m Ω , $\pm 10\%$ or $\pm 1m\Omega$	
	Temperature	- 20...80°C, $\pm 2^\circ\text{C}$	
Protections	-Reverse polarity (active) -Overvoltage (passive)		
Battery connection	Blade connector (Faston), ring or alligator clip; others possible on demand		

IDAM	Type 1 (300A)	Type 2 (600A)
Supply input range	9...18VDC(from external power supply or battery)	
Current consumption (typical)	50mA @ 12V (Sleep mode: 15mA)	
Plug-in AC adapter	- Input: 100..240Vac / 500mA, 50..60Hz - Output: 12Vdc / 1.67A	
RF	- 868.00-868.60MHz, Max EIRP 4mW, 3 channels user settable - Up to 100 meters outdoor, up to 30 meters indoor	
Current Range	<i>40A range:</i> 0...40A, $\pm(1.5\% + 0.4A)$ <i>300A range:</i> 0...200A, $\pm(1.5\% + 2A)$ 200...300A, $\pm(2.4\% + 3A)$	<i>100A range:</i> 0...100A, $\pm(3\% + 3A)$ <i>600A range:</i> 0...400A, $\pm(3\% + 4A)$ 400...600A, $\pm(4\% + 4A)$
Weight	- IDAM module: 40g - Current clamp: 200g	- IDAM module: 40g - Current clamp: 250g
Protections	- Reverse polarity (active) - Overvoltage (passive)	

Table 2: Devices characteristics

Note: Referred values are typical. In order to improve the product specifications may change without prior notice.